

AVerMedia

**EYES Pro/
MP2016/MP3000/MP5000**

Digital Video Surveillance System

User's Manual

300AABCK/400/0616

FCC NOTICE

This device has been tested and found to comply with the limits for a Class A digital device, pursuant to Part 15 of the FCC Rules. These limits are designed to provide reasonable protection against harmful interference in a commercial, industrial or business environment. This equipment can generate, use and radiate radio frequency energy and, if not installed and used in accordance with the instruction, may cause harmful interference to radio communications. However, there is no guarantee that interference will not occur in a particular installation. If this equipment does cause harmful interference to radio or television reception, which can be determined by turning the equipment off and on, the user is encouraged to try to correct the interference by one or more of the following measures:

- Reorient or relocate the receiving antenna.
- Increase the separation between the equipment and receiver.
- Connect the equipment into an outlet on a circuit different from that to which the receiver is connected.
- Consult the dealer or an experienced radio/TV technician for help.

This device complies with Part 15 of the FCC Rules. Operation is subject to the following two conditions: (1) this device may not cause harmful interference, and (2) this device must accept any interference received, including interference that may cause undesired operation.

CAUTION ON MODIFICATIONS

To comply with the limits for the Class A digital device, pursuant to Part 15 of the FCC Rules, this device must be installed in computer equipment certified to comply with the Class A limits. All cables used to connect the computer and peripherals must be shielded and grounded. Operation with non-certified computers or non-shielded cables may result in interference to radio or television reception.

Any changes or modifications not expressly approved by the grantee of this device could void the user's authority to operate the equipment.

CE NOTICE

This is a Class A product.

ENG 02

DISCLAIMER

No warranty or representation, either expressed or implied, is made with respect to the contents of this documentation, its quality, performance, merchantability, or fitness for a particular purpose. Information presented in this documentation has been carefully checked for reliability; however, no responsibility is assumed for inaccuracies. The information contained in this documentation is subject to change without notice.

In no event will AVerMedia be liable for direct, indirect, special, incidental, or consequential damages arising out of the use or inability to use this product or documentation, even if advised of the possibility of such damages.

TRADEMARKS















AVerMedia is a trademark of **AVerMedia® TECHNOLOGIES, Inc.** IBM PC is a registered trademark of International Business Machines Corporation. Microsoft is a registered trademark and Windows is a trademark of Microsoft Corporation. All other products or corporate names mentioned in this documentation are for identification and explanation purposes only, and may be trademarks or registered trademarks of their respective owners.







COPYRIGHT





© 2002-2003 by **AVerMedia® TECHNOLOGIES, Inc.** All rights reserved. No part of this publication may be reproduced, transmitted, transcribed, stored in a retrieval system, or translated into any language in any form by any means without the written permission of **AVerMedia® TECHNOLOGIES, Inc.**

Table of Contents

CHAPTER 1 INTRODUCTION	1
1.1 Manual Conventions	1
1.2 Video Card Specification	2
1.3 Package Contents	2
1.4 Hardware Recommendations	3
1.5 Installing the Video Cards	5
1.6 Connecting the AVerMedia Video Cards	8
1.7 Attaching Cameras	8
1.8 Connecting External Sensor/Relay	9
CHAPTER 2 DRIVER INSTALLATION	13
2.1 Installing the Driver in Windows 98SE/Me	13
2.2 Installing the Driver in Windows 2000	18
2.3 Installing the Driver in Windows XP	23
2.4 Remove Your Video Card Driver	26
CHAPTER 3 SOFTWARE INSTALLATION	27
3.1 Installing AVerMedia EYES Pro/MP2016/MP3000/ MP5000 Software	27
3.2 Product Update	32
3.3 Special Consideration	33

CHAPTER 4 SYSTEM CONFIGURATION AND OPERATION	34
4.1 System Configuration	34
 System	37
 Cameras	42
 Audio	45
 Monitoring	47
 Sensors	50
 Relays	51
 Alarms	53
 Networking	58
 Scheduler	61
 Backup	67
 E-Map	72
 Users Information	74
4.2 System Operation	78
 Start / Stop Monitoring	83
 Start / Stop Audio Recording	83

	E-Map	84
	Load / Close Network Server	85
	System Configuration.....	85
	Log Viewer	86
	PTZ Controller.....	95
	Status Monitoring	98
	Exit / Re-login EYES Pro/MP2016/MP3000/MP5000	101
CHAPTER 5 USING THE WEBCAM.....		102
5.1	Enable WebCam.....	102
5.2	Use the WebCam	104
CHAPTER 6 REMOTEMANAGER		106
6.1	Accessing RemoteManager	106
6.2	 Setup.....	108
6.3	Operating the RemoteManager	115

6.3.1		Center Management.....	115
6.3.2		Playback.....	118
6.3.3		PTZ Control	122
6.4		Start Recording	125
6.5		Exit RemoteManager	125

APPENDIX A REMOTE LOGIN WITH AN MODEM-TO-MODEM

CONNECTION	126	
A.1	Windows 98SE / Windows Me	126
A.2	Windows 2000.....	131
A.3	Windows XP	138

APPENDIX B REGISTERING DOMAIN NAME ON DDNS SERVER

LIMITED WARRANTY.....	149
------------------------------	------------

Chapter 1 Introduction

Welcome to the realm of AVerMedia. AVerMedia EYES Pro /MP2016/MP3000/MP5000, composed of one 32-bit PCI video capture card, works as a digital video surveillance system. It allows you to capture true color images and real-time videos from 4/8/16 camera input(s) simultaneously.

With the latest Motion Detection technology, once any movement detected in the monitoring area, AVerMedia EYES Pro/MP2016/MP3000/MP5000 automatically starts recording and triggers the alarm. You don't need to keep your eyes on the monitor all day long anymore; the system will alert you automatically when specified events occur.

1.1 Manual Conventions

The following conventions are used throughout this manual.

Type	Stands for	Example
[paren.]	Keys on the keyboard	[Enter]
"Quotes"	Words to be typed in	"AVerMedia"
Italic	User in each authorization level	<i>Administrator</i>
Bold	Name of a dialog box, Sections/Option title in the dialog box/Field names/Buttons	Schedule Backup
Underlined	Table columns	<u>Start</u>



Caution Message: These messages are to advise you to proceed carefully. Failure to pay attention could result in damage to the system and may put personnel and environment at risk.



Informational Message: These messages are intended to provide additional information for the purpose of clarification.

1.2 Video Card Specification

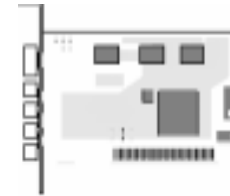

4 ports

Product	Video Card	Specifications
4 EYES Pro	1 card	Each video capture card with 4 video inputs
8 EYES Pro	2 cards	Each video capture card with 4 video inputs
16 EYES Pro	4 cards	Each video capture card with 4 video inputs
MP3004	1 card	Each video capture card with 4 video inputs
MP3008	1 card w/ 1 daughter card	Each video capture card with 4 video inputs
MP2016/MP3016	1 card w/ 3 daughter cards	Each Video capture card with 4 video inputs
MP5004	1 card	Each video capture card with 4 video inputs
MP5008	1 card w/ 1 daughter card	Each video capture card with 4 video inputs
MP5016	2 cards w/2 daughter cards	Each video capture card with 4 video inputs



AVerMedia has been dedicated to innovating the technology of digital video surveillance system. We have had a significant innovation on promoting hardware that is presented as the part of MP series above.

1.3 Package Contents

Your AVerMedia EYES Pro/MP2016/MP3000/MP5000 package includes the following :



AVerMedia User's Manual
EYES Pro/MP2016/MP3000/MP5000

- 1 / 2 / 4 AVerMedia Video Card(s) for EYES Pro
- 1/2 AVerMedia Video Card(s) and 1/3 daughter card(s) for MP2016/MP3000/MP5000
- AVerMedia EYES Pro/MP2016/MP3000/MP5000 Software CD (Including Driver, Application Software, and User's Manual)
- AVerMedia EYES Pro/MP2016/MP3000/MP5000 User's Manual
- Optional external I/O Box and 15-pin D-type Connector Cable



1.4 Hardware Recommendations

CPU	Pentium® III 800MHz or above recommended
Motherboard	Intel 815E/815EP (PIII), 845(P4), 845D(P4), 845E(P4), 845G(P4) List of motherboards tested: <ul style="list-style-type: none"> • ASUS P4B • ASUS P4B266 • ASUS P4B533 • ASUS P4B533-V • GIGABYTE 8IRX • GIGABYTE 8IEX • GIGABYTE 8IEXP • GIGABYTE 8IGX • MSI 845E Max2 • MSI 845G Max (VIA/SiS/ALi chipset motherboards temporarily not supported)
OS	Microsoft® Windows 98SE/Me/2000 Pro. /XP Pro.
Expansion Slots	1 / 2 / 3 / 4 × 32-bit PCI 2.1 compliant slots
RAM	<ul style="list-style-type: none"> • Transcend DDR 256MB (DDR-266) • KingSton DDR 256MB (DDR-266) • KingMax SDRAM 256MB (PC-133) • KingMax DDR 256MB(DDR-333)

AVerMedia User's Manual
EYES Pro/MP2016/MP3000/MP5000

Hard disk	40 GB of free hard disk space, at least 6GB free space for each partition.
HDD	<ul style="list-style-type: none"> • Seagate ST340016A (40G 7200rpm) • Seagate ST380021A (80G 7200rpm)
Media	CD-ROM drive
VGA	16-bit high color SVGA graphic card with DirectDraw capability List of VGA Cards tested: <ul style="list-style-type: none"> • Leadtek WinFast GeForce2 MX400 • Leadtek WinFast A170 DDR TDH • Leadtek WinFast 3D S325 32MB • Leadtek WinFast A250 TD 128MB • ATI RADEON 8500 64MB/128MB • ELSA GLADIAC 525 128MB • ELSA GLADIAC 517 VIVO 64MB
Audio	Sound card and speakers
Modem	List of modems tested: Modem2modem feature Internal: <ul style="list-style-type: none"> • USR 5699A (Chipset: 3COM) • Creative Lab DI5630 (Chipset: Broadxent) • SmartLink 5634PSV-R • QDK Speedcom+ VPI56SP (Chipset: Conexant) • GVC 56K V.90 Voice/Fax (Chipset: Motorola) • CyberMarmot Rock Modem (Chipset: Ambient) • Lemel MD-56KVR4 (Chipset: Conexant) External: <ul style="list-style-type: none"> • USR 5686D (Chipset: USR) • GVC 56Kbps (Chipset: Rockwell) • Atrie Explore (Chipset: Conexant) • Zyxel Omni 56K Data/Voice (Chipset: Zyxel) • SmartLink 56TS (Chipset: TI) • SmartLink 56TPC (Chipset: IC+) • ART NET V1456VQE (Chipset: TOPIC) • Well USB Soft Modem FM-56USB-ST (USB interface)

Modem	<p>Alarm call out feature</p> <p>Internal:</p> <ul style="list-style-type: none"> • Creative Lab DI5630 (Chipset: Broadxent) • Creative Lab DI5630-5 (Chipset: Broadxent)
-------	---

 For the current update information, please check our website.

1.5 Installing the Video Cards

1.5.1 Installing the AVerMedia EYES Pro Video Cards

The following instructions are for installing video cards into the AVerMedia EYES Pro system.

 Before installing the video card, turn off the computer's power, unplug the power cable and disconnect all other cables attached to the back of the computer.

Video Card



Video card

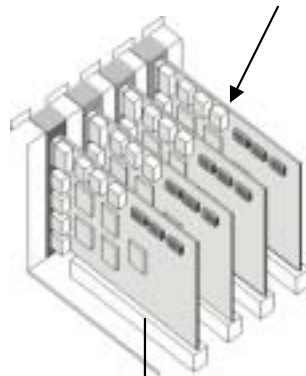

PCI Slot

1. Remove the computer cover.
2. Remove the I/O brackets for the four PCI expansion slots. Save the screws.
3. Insert the AVerMedia video cards into the available PCI expansion slots.
4. Replace the computer cover and reconnect all cables.

1.5.2 Installing the AVerMedia MP2016/MP3000/MP5000 Video Cards

The following instructions are for installing video cards into the AVerMedia MP2016/MP3000/MP5000 system.

 Before installing the video card, turn off the computer's power, unplug the power cable and disconnect all other cables attached to the back of the computer.

MP3004/MP5004/MP5008
Video card

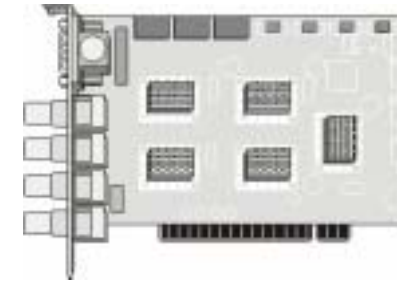

MP3008/MP5016
Video card

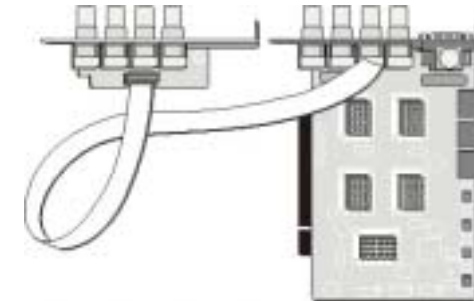

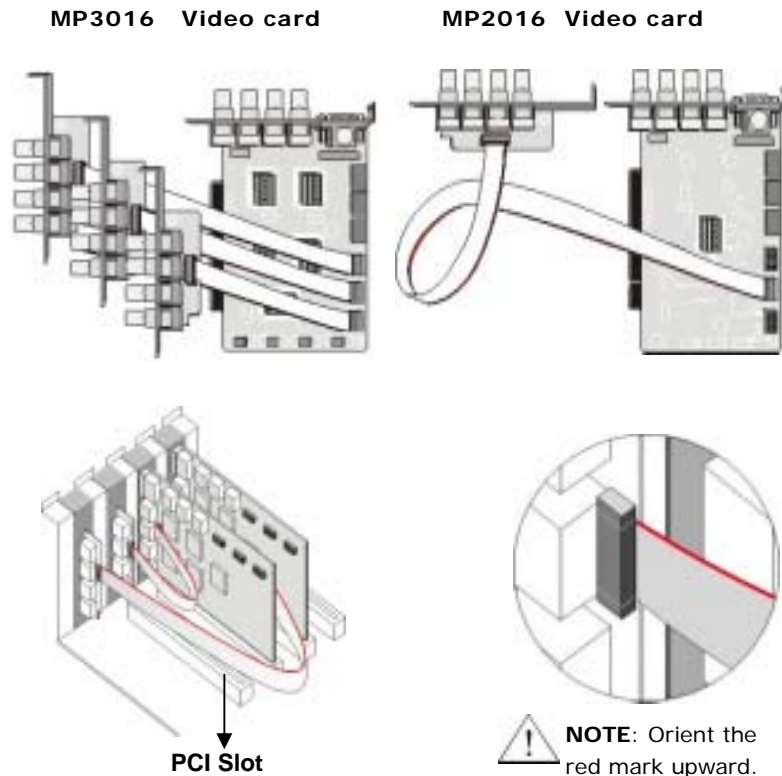

Fig. 1

Fig. 2

1. Remove the computer cover.
2. Remove the I/O brackets for the four PCI expansion slots. Save the screws.
3. Align AVerMedia video card connector with the available PCI slots.
4. Screw AVerMedia video card and the 3 daughter cards respectively into the rear panel with the screws. See the Fig.1.
5. Connect the 3 daughter cards to AVerMedia video card with ribbon cables. See the Fig.2.
6. Replace the computer cover and reconnect all cables.

1.6 Connecting the AVerMedia Video Cards

Up to four cameras can be connected to each AVerMedia video card - one camera per BNC terminal.

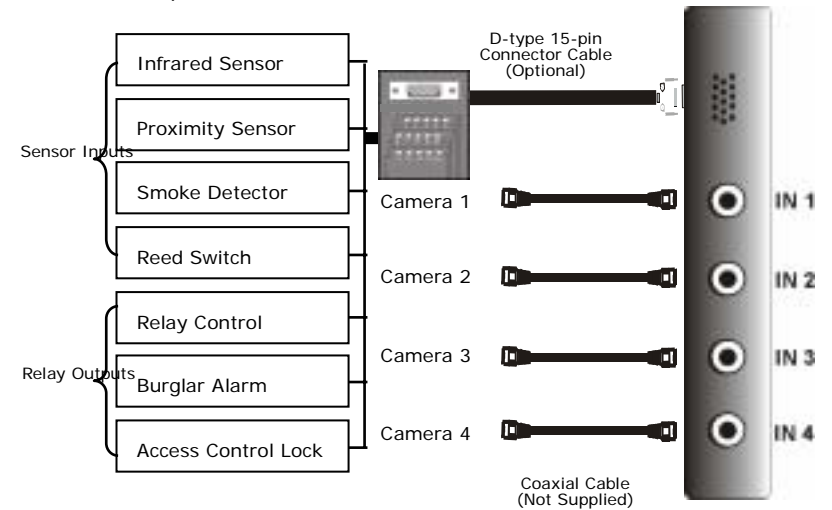

1.7 Attaching Cameras

Cameras must be attached to the BNC connectors of the server video cards in a specific order to avoid transmission problems. Video cards are stacked vertically into the chassis. If all four video cards are installed, the rear panel of the server will appear as shown in the diagrams below.

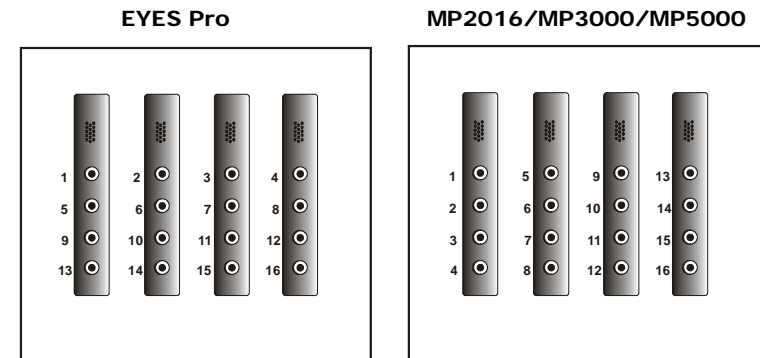

Cameras need to be installed according to the numerical order displayed on the diagrams above. Whether you have one, two, three or four video cards, the pattern is the same - **cameras will be installed from left to right starting with the top row for EYES Pro and from top to bottom beginning with the left-most column for MP2016/MP3000/MP5000.**

1.8 Connecting External Sensor/Relay

Each system can come with optional External I/O Boxes and D-type 15-pin connector cables enabling you to connect sensor inputs and relay outputs. The pin signals and specifications for the external I/O Box and the D-type 15-pin connectors are described below.

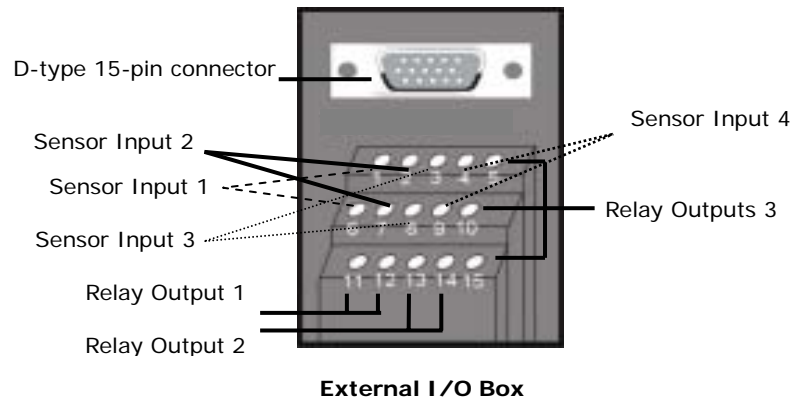
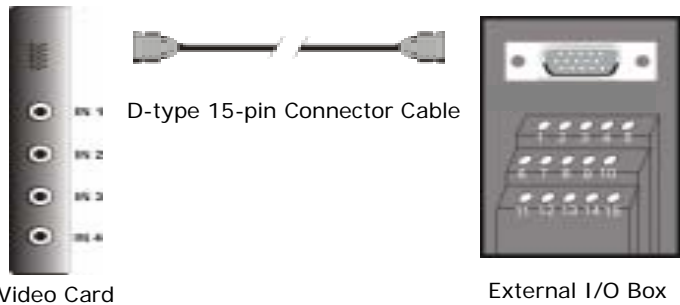

External I/O Box

Sensor Input Specification

Parameter		Symbol	Rating	Unit
Input	Forward Current	I _F	30	mA
	Reverse Voltage	V _R	5	V
	Power Dissipation	P	75	mW

Parameter		Symbol	Min.	Typ.	Max.	Unit	Conditions
Input	Forward Voltage	V _F	—	1.2	1.4	V	I _F =20mA
	Reverse Current	I _R	—	—	18	μA	V _R =5V
	Terminal Capacitance	C _T	—	30	250	pF	V _R =0, f=1MHz
Output	Collector Dark Current	I _{CO}	—	—	100	nA	V _{CE} =25V
	Collector-Emitter Breakdown Voltage	V _{CE(su)}	35	—	—	V	I _C =0.1mA
	Emitter-Collector Breakdown Voltage	V _{EC(su)}	6	—	—	V	I _E =10 mA
Transfer Characteristics	Current Transfer Ratio	CTR	30	—	600	%	I _C =1mA, V _{CE} =4V, P _{tot} =—
	Collector Current	I _C	2.5	—	30	mA	
	Collector-Emitter Saturation Voltage	V _{CE(sat)}	—	0.1	0.2	V	I _C =20mA, I _E =1mA
	Isolation Resistance	R _{iso}	5 × 10 ⁷	10 ⁷	—	Ω	DC500V, 40–60% R.H.
	Peak-to-Peak Capacitance	C _T	—	0.6	1.0	pF	V _R =0, f=1MHz
	Cut-off Frequency	f _c	—	30	—	kHz	V _{CE} =5V, I _C =2mA, R _L =100 Ω, R _{in} =300 Ω
Response Time (Rise)	t _r	—	4	18	ns	V _{CE} =2V, I _C =2mA, R _L =100 Ω	
Response Time (Fall)	t _f	—	3	18	ns	R _L =100 Ω	

CTR = I_C / I_F × 100%

Relay Output Specification

Surge strength: 1500 VAC
 Nominal power 200mw ~ 360mw
 Operating power 110mw ~ 200mw

COIL RATINGS (at 20°C)

Coil Nominal Voltage (VDC)	Coil Resistance (Ω ±10%)	Pick-up Voltage (VDC)	Drop-Out Voltage (VDC)	Nominal Current (mA)
5	125	3.75	0.5	40

* Max Continuous Voltage at 20°C : 110% of Coil Nominal Voltage

CONTACT RATINGS

Contact Arrangement	1 Form C (SPDT)
max. Switch Power	125VA 60W
max. Switch voltage	125VAC 30VDC
max. Switch current	2A
Contact Resistance	$\leq 100\text{m } \Omega$
Resistive Load	1A/125VAC 2A/30VDC
Contact Material	AgNi10

External I/O Box Pin Signals

Pin #	Definition
1	INPUT SIGNAL 1+
2	INPUT SIGNAL 2+
3	INPUT SIGNAL 3+
4	INPUT SIGNAL 4+
5	OUTPUT 3 – Normally Closed
6	INPUT SIGNAL 1-(GND)
7	INPUT SIGNAL 2-(GND)
8	INPUT SIGNAL 3-(GND)
9	INPUT SIGNAL 4-(GND)
10	OUTPUT 3 – Common
11	OUTPUT 1 – Normally Open
12	OUTPUT 1 – Common
13	OUTPUT 2 – Normally Open
14	OUTPUT 2 – Common
15	OUTPUT 3 – Normally Open

Sensor Inputs

External sensors such as infrared sensors, smoke detectors, proximity sensors, door sensors, etc., can be attached to the AVerMedia EYES Pro/MP2016/MP3000/MP5000's input-signal connectors on the External I/O Box. These devices trigger the system to respond with a predefined action (e.g. record video)

Relay Outputs

The AVerMedia EYES Pro/MP2016/MP3000/MP5000's output connectors (relay output) can be attached to external output control devices such as alarms. The system can be configured to activate or deactivate these devices. Each AVerMedia video card supports three relay outputs. Two of them are normally open relays with one being a toggle switch.

Chapter 2 Driver Installation

AVerMedia EYES Pro/MP2016/MP3000/MP5000 are Plug-and-Play digital surveillance systems that support Windows 98SE/Me/2000/XP. To start using this system, first install the drivers and application software from the Software CD that comes with AVerMedia EYES Pro/ MP2016/MP3000 /MP5000 system.



Check Your Windows Version

Before you install the driver, check to see whether you are using Windows 98SE, Windows Me, Windows 2000 or Windows XP. To do this, click **Start → Settings → Control Panel** on the Window's toolbar, and then double-click System. You will see the Windows version under the General tab.

Depending on the version you use, you will encounter different dialog boxes when installing the driver. Those listed in the following sections are for installing drivers in Windows 98SE/Me, Windows 2000 and Windows XP.

2.1 Installing the Driver in Windows 98SE/Me

After you have properly installed the AVerMedia video card in your computer, power on your computer and start Windows 98SE/Me.

1. The first time you install the AVerMedia video card driver, you will see the **Add New Hardware Wizard**. Insert the Software CD and click the **Next** button.



2. Select **Search for the best driver for your device. (Recommended)** and then click the **Next** button.

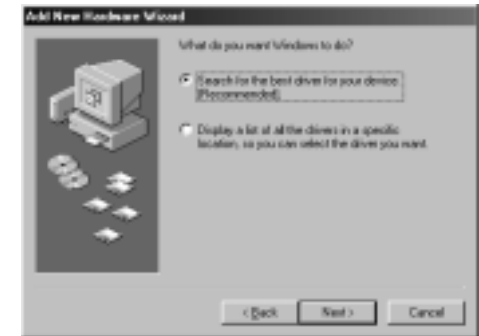

3. Choose **Specify a location** and click the **Browse** button to find the drivers in the **[driver]** folder of the EYES Pro /MP2016/MP3000 /MP5000 Software CD. Click the **Next** button.

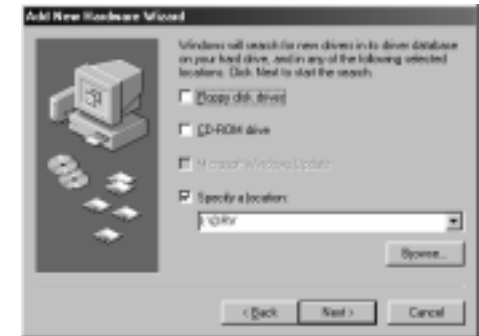

4. The **Add Hardware Wizard** will find ARGUS.inf from the folder you specified. Click the **Next** button to continue.



5. (For Windows 98SE only) Insert the Windows 98SE CD-ROM to start installing the driver.



6. Click the **Finish** button to complete the installation of video driver.

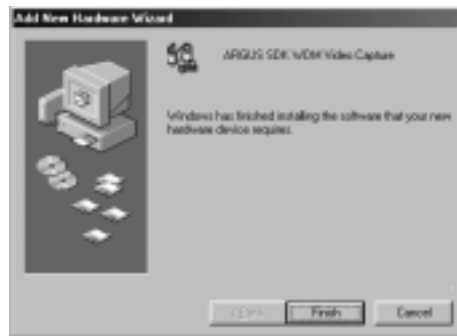

7. Next you need to install the audio driver. Click the **Next** button to proceed.

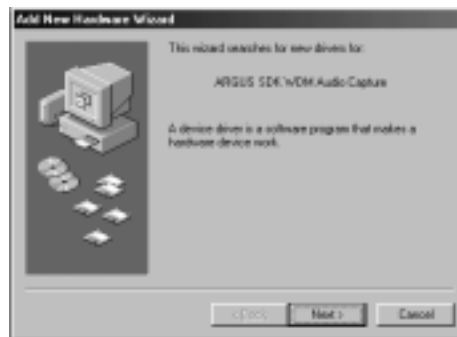

8. Select **Search for the best driver for your device. (Recommended)** and click the **Next** button.



9. Select **Specify a location** and click the **Next** button.

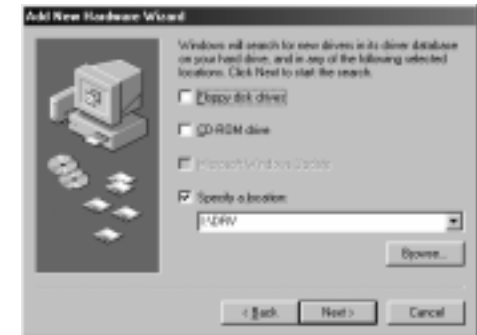

10. The system will find the video driver you just installed because the audio driver is the same as the video driver. Click the **Next** button to continue.



- Click the **Finish** button to complete the audio driver installation and reboot your PC.



For EYES Pro, you need to take the procedures (1~14) once for each video card. For MP3000, you are asked to repeat the procedures 4 times; for MP2016/MP5000 8 times at most. If you have installed 4 video cards, you will find the system's device manager looking like the following figure.

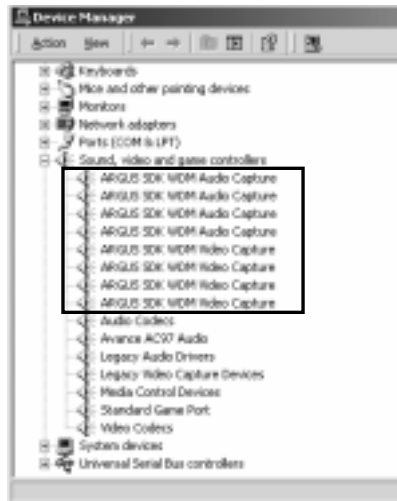

2.2 Installing the Driver in Windows 2000

After you have properly installed the video card in your computer, power on your computer and start Windows 2000.

- The first time you install the video card, you will see the **Found New Hardware Wizard**. Insert the EYES Pro/MP2016/MP3000/MP5000 Software CD and click the **Next** button.



- Select **Search for a suitable driver for my device (recommended)** and click the **Next** button.

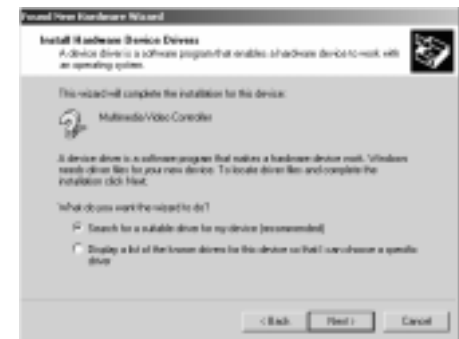

- Select **Specify a location** and click the **Next** button.



- You'll be prompted to enter or browse the location of the video card driver. Set the right path and click the **OK** button.



- The system will find argus.inf from the folder you specified. Click the **Next** button to continue.



- Click the **Yes** button to proceed with the installation.

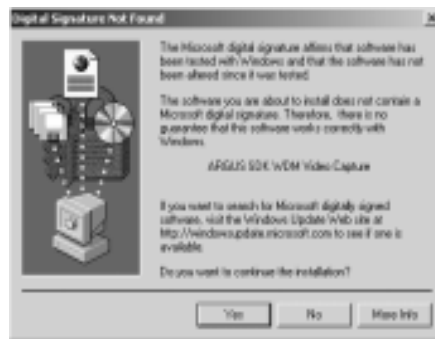

- The system will soon show that it has finished the video driver installation. Click the **Finish** button.



- Next you need to install the audio driver. Click the **Next** button to proceed.



- Select **Search for a suitable driver for my device (recommended)** and click the **Next** button.



10. Check **Specify a location** and click the **Next** button.



11. You'll be prompted to enter or browse the location of the AVerMedia video card driver. Set the right path and click the **OK** button.



12. The system will find the video driver you just installed because the audio driver is the same as the video driver. Click the **Next** button to start installing.



13. Click the **Yes** button to proceed with the installation.

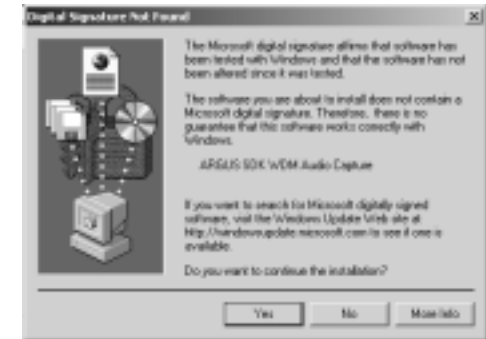

14. Click the **Finish** button to complete the installation and reboot your PC.



For EYES Pro, you need to take the procedures (1–14) once for each video card. For MP3000, you are asked to repeat the procedures 4 times; for MP2016/MP5000 8 times at most. If you have installed 4 video cards, you will find the system's device manager looking like the following figure.

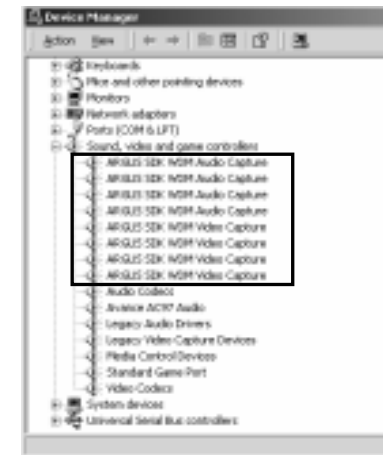

2.3 Installing the Driver in Windows XP

After you have properly installed the video card in your computer, power on your computer and start Windows XP.

1. The first time you install the video card, you will see the Found New Hardware Wizard. Insert the EYES Pro/MP2016/MP3000/MP5000 Software CD and select **Install the software automatically (recommended)**. Click the **Next** button.



2. The system will then find the driver argus.inf in the Software CD and start installing. When this dialog box shows up, click the **Continue Anyway** button to proceed.

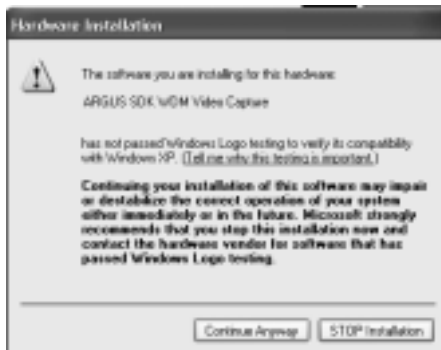

3. After the installation finished, click the **Finish** button.



4. You need to continue installing the audio driver. Select **Install the software automatically (recommended)** and click the **Next** button.



5. Because the audio capture uses the same driver as the video capture, the system will find the video driver you just installed and start installing. When this dialog box appears, click the **Continue Anyway** button.

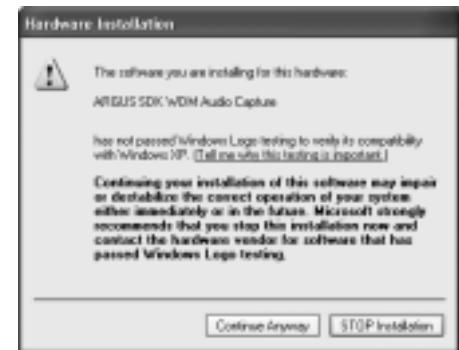

6. After the installation finished, click the **Finish** button.



For EYES Pro, you need to take the procedures (1~14) once for each video card. For MP3000, you are asked to repeat the procedures 4 times; for MP2016/MP5000 8 times at most. If you have installed 4 video cards, you will find the system's device manager looking like the following figure.

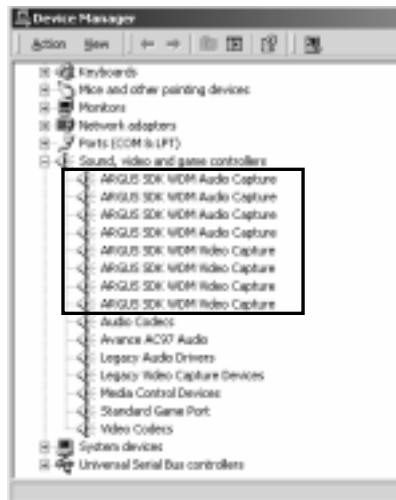

2.4 Remove Your Video Card Driver

While removing your video card driver, you need to follow the steps described below.

1. Find the system's **Device Manager**, ungroup **Sound, video and game controllers**, and remove all the drivers by the names of **"ARGUS WDM Audio Capture"** and **"ARGUS WDM Video Capture"**

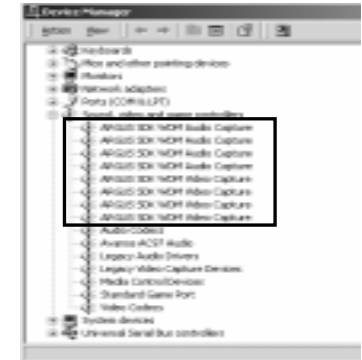

2. Delete the following files in the specified paths.
 - Windows 98/Me:
C:\WINDOWS\INF\OTHER\DVR\ARGUS.inf
C:\WINDOWS\SYSTEM32\DRIVERS\argus.sys
 - Windows 2000:
*C:\WINNT\INF\oemX.inf
*C:\WINNT\INF\oemX.pnf
C:\WINNT\SYSTEM32\DRIVERS\argus.sys
 - Windows XP:
*C:\WINDOWS\INF\oemX.inf
*C:\WINDOWS\INF\oemX.pnf
C:\WINDOWS\SYSTEM32\DRIVERS\argus.sys

* For the files **"oemX.inf"** and **"oemX.pnf,"** "X" stands for numbers. Open each of the **oemX.inf** and locate the **[Manufacturer]** section. If the value is **DVR**, then this is the file you need to delete. For **oemX.pnf**, delete the one that has the same number (X) as the **oemX.inf** you deleted. For example, if **oem0.inf** has **DVR** in the **[Manufacturer]** section, then you need to delete both **oem0.inf** and **oem0.pnf**.

3. Please reboot your computer to complete the remove.

Chapter 3 Software Installation

3.1 Installing AVerMedia EYES Pro/MP2016/MP3000/MP5000 Software

After you successfully install the video card driver, you then are ready to install the EYES Pro/MP2016/MP3000/MP5000 application software. You can easily complete the installation of AVerMedia EYES Pro/MP2016/MP3000/MP5000 by following the simple instructions below.

i During the installation, you will be asked to key in a user name and a password. You must remember them because you will be prompted for entering the same user name and password later when entering the AVerMedia EYES Pro/MP2016/MP3000/MP5000 surveillance system.

i It's recommended that you exit all other Windows programs before you install AVerMedia EYES Pro/MP2016/MP3000/MP5000 surveillance system.

1. Insert the AVerMedia EYES Pro/MP2016/MP3000/MP5000 CD into the CD-ROM drive and wait for it to auto-run.
2. Click the text "AVerMedia EYES Pro", "AVerMedia MP2016", "AVerMedia MP3000", or "AVerMedia MP5000" and choose the language version you would like to install.



3. The system will then start preparing to install the AVerMedia EYES Pro/MP2016/MP3000/MP5000 application software.

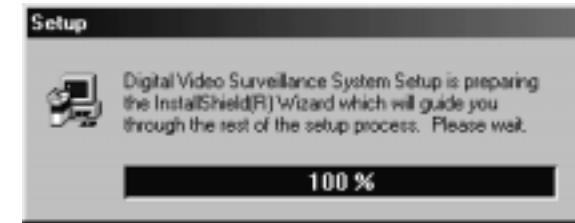

4. Click the **Next** button to continue.



5. Read the License Agreement and click the **Yes** button if you accept it; otherwise click the **No** button to exit the setup program.

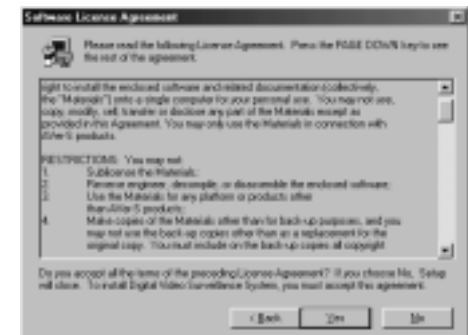

6. Enter your Name, Company Name, and the Serial No. (printed on the CD cover) and click the **Next** button. The name you enter here will be used as the *System Manager* when operating the software.



7. Choose the components you need and then designate the destination folder for the software to be installed. Click the **Next** button to continue.



8. Specify the folder name to store the AVerMedia EYES Pro/MP2016/MP3000/MP5000 program or choose an existing folder from the list. Click the **Next** button.



9. Select the video format of the camera used in your country. If you don't know the correct format, contact your local camera supplier. Click the **Next** button.



10. Set a password for the *System Manager*. You need to use this password when entering the EYES Pro/MP2016/MP3000/MP5000 system. Click the **Next** button to continue. The system then starts to install the software.



11. Select the number of video channels you will use on this system and click the **Next** button.



12. After the installation finishes, you can choose to create a shortcut of EYES Pro/MP2016/MP3000/MP5000 program and click the **Next** button.



13. Before you exit the setup program, you can choose to view the README file. After you click the **Finish** button, a text file will show up.



14. Choose whether you like to restart your computer now or later and click the **Finish** button to complete the installation.



3.2 Product Update

To obtain the latest software, go to www.avers.com.tw to download the updated software of AVerMedia EYES Pro/MP2016/MP3000/MP5000 system. After you successfully download the file, follow the procedures below to update your software.

1. First you need to remove the older-version software from your computer. Go to **Control Panel** and double-click on **Add/Remove Programs**. Select "**Uninstall Digital Video Surveillance System**" and click the **Add/Remove** button. You will need to reboot the system afterwards.
2. Update your new AVerMedia software. Refer to section 3.1 – Software Installation. It is unnecessary to update a new driver manually because the system will execute the procedure automatically during installation.

If your MP3000 series video card driver is beyond version 3.5, notice that the innovation on hardware in V 3.5 has restrained you to update the entire services, which is described as follows:

Product	Present H/W	Update Solution H/W	Update Solution S/W
MP 3004	1 card	1 card	4 chs
MP 3008	2 cards	1 card	4 chs
MP 3016	2 sets of 1 card w/ 1 extended card	1 card	4 chs
		1 card w/ 1 extended card	8 chs



After finishing updating, select the desired channel numbers and disable the unselected channels for keeping the efficiency of the system while reinstalling video card driver.

3.3 Special Consideration

Defrag Your Hard Disk

Files on your hard disk will unavoidably become fragmented. Fragmentation occurs when the operating system must split files into parts and fit each part into different free segment of the hard disk to make full use of the hard disk space. If files on your hard disk become excessively fragmented, your system would have to work very hard to maintain all the necessary information about the files locations. This results in slow and bogged-down performance and it gets more and more serious as the time goes on. Therefore, it is recommended that you regularly run a defragment utility program on your hard disk such as Windows Disk Defragmenter especially before you start saving recorded videos to the hard disk.

Chapter 4 System Configuration and Operation

 Before you start running the EYES Pro/MP2016/MP3000/MP5000 system, please set your monitor resolution to 1024 x 768 and the color to 16-bit true color or above.

4.1 System Configuration

When you first start up the AVerMedia EYES Pro/MP2016/MP3000/MP5000, the system will request you to enter user ID and password to login surveillance system. **Key in the user name and password you entered during the EYES Pro/MP2016/MP3000/MP5000 installation.**



Upon the success of authentication, you will see the following main screen of EYES Pro/MP2016/MP3000/MP5000 Digital Video Surveillance System.

EYES Pro/MP2016/MP3000/MP5000 Main Screen

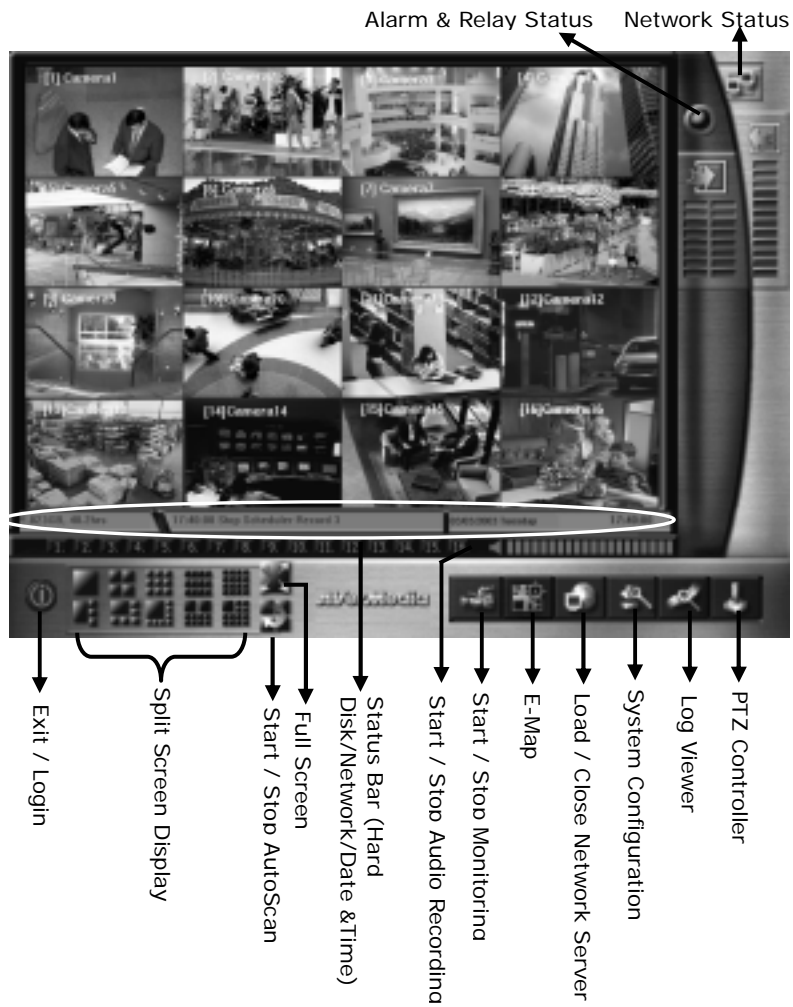

Click the  **System Configuration** button to enter the configuration dialog. You need to first set up your surveillance system before you start using it.



After entering the System Configuration page, you can set up the system, cameras, audio, monitoring, sensors, relays, alarms, networking, scheduler, backup, e-map, and user information.

System

Clicking on  **System** brings you to the following dialog box for system information. Here you need to provide some basic information for the monitoring and recording operation.

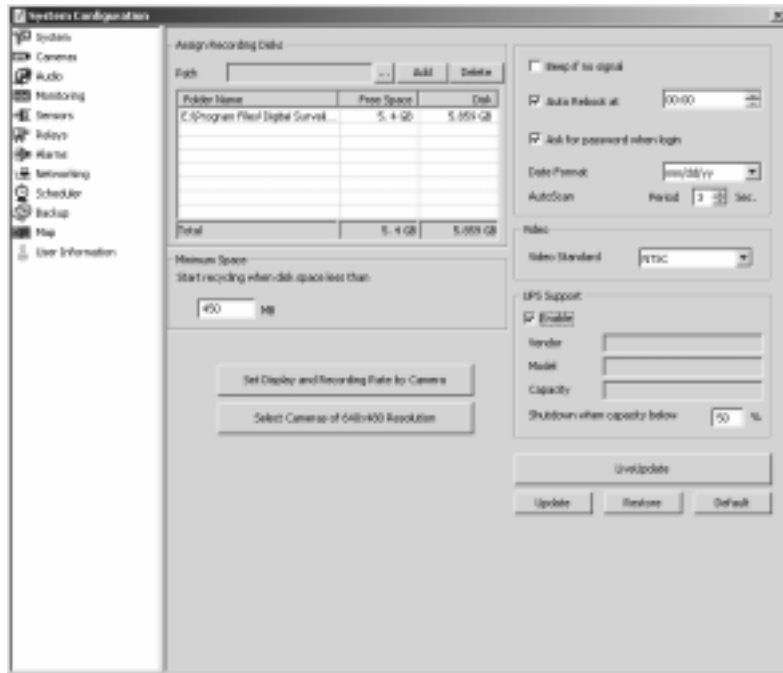

1. Assign Recording Disks

First you need to assign the recording disks. Click  to browse for the folder to save the recorded videos and click the **Add** button. You can click the **Delete** button to remove any of the recording disks, as long as there is at least 1 disk left to save the recording data.

2. Minimum Space

Next you need to provide the minimum space for hard disk recycling. During hard disk recycling, the newly recorded files will overwrite the old ones. This way the system will not run out of hard disk space to save the recorded videos. The system will start hard disk recycling when the hard disk free space is less than a user-defined number. The user-defined number has to be greater than 450MB, the system defaults to 450MB.

3. Miscellaneous



Beep if no signal:

Check this box to have the system start beeping whenever a video loss from a camera occurs.

Auto Reboot:

For better system performance and stability, it is recommended for you to check the Auto Reboot box and the system will reboot everyday at a user-defined hour that least interferes with your surveillance operation.

Ask for password when login:



Check this box to enable the password protection when users login the surveillance system.

Date Format:

Here you can choose to show the date information in the order of mm/dd/yy, yy/mm/dd, or dd/mm/yy.

AutoScan:

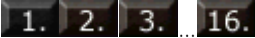
This function allows you to view each camera image in numerical sequence under 1-Cam Display mode. Check AutoScan to enable this function and define the scan interval from 1 to 60 seconds (defaults 3 seconds). When in this function is enabled, you need to

return to the main menu and click  to start the AutoScan function. During AutoScan, you can click  Focus Camera to jump to any camera. To stop the AutoScan function, click  again.

4. Video

For Video Standard, you need to choose from NTSC and PAL according to the system you are using.

5. Display & Recording Rate



With this button you can set display and recording rate by camera. You will see the following dialog box when you click this button. There are 5 levels of display and recording rate. Drag the bar to adjust the display/recording rate for each camera.

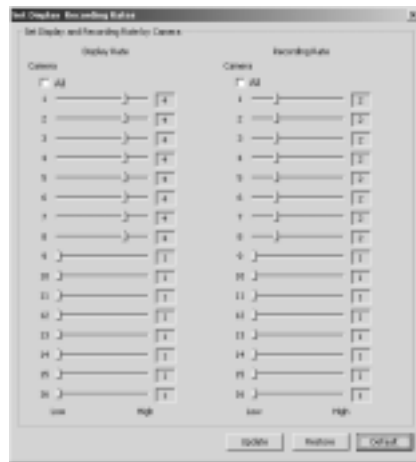

In case **All** is checked, you will see that while you're adjusting the rate for one camera, the rate of other cameras will be adjusted at the same time. Cameras that are adjusted together use the same video chip on the video capture card.

6. 640 x 480 Resolution

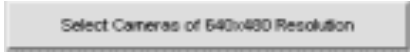

The utility provides your particular demand on the better 640 x 480 resolution for the specific cameras. For EYES Pro/MP2016/MP3000, you can check the cameras to perform the better resolution by clicking this button. Note that those cameras are arranged to be sets according to the same video chipset on the video capture card. For MP5000, you can set all cameras randomly to perform 640 x 480 resolution. The arranged camera sets are listed as follows:

Product	Camera Sets
4 EYES Pro	1,2,3,4
8 EYES Pro	1,2,3,4 5,6,7,8
16 EYES Pro	1,2,3,4 5,6,7,8 9,10,11,12 13,14,15,16
MP2016	1,2,3,4,5,6,7,8,9,10,11, 12,13,14,15,16
MP3004	1, 2, 3, 4
MP3008	1,5 2,6 3,7 4,8
MP3016	1,5,9,13 2,6,10,14 3,7,11,15 4,8,12,16
MP5004	1 2 3 4
MP5008	1, 2, 3, 4, 5, 6, 7, 8
MP5016	1,9 2,10 3,11 4,12 5,13 6,14 7,15 8,16



 That too many cameras were selected to be 640 x 480 resolution will result in overloading for system. For the further information please refer to our website: www.avers.com.tw

7. UPS (Uninterruptible Power Supply)

It enhances the security for system to warn administrators and users if AC power fails and proceeds with system shutdown before the end of battery backup power is reached. The UPS device should be connected to your computer (refer to your UPS user's guide) before the presetting of this task.

- A. Check **Enable** to activate UPS meanwhile the **Vendor** as well as **Model** of your UPS will show up in the individual boxes if your UPS is completely connected to.
- B. Determine a limited value for capacity to shutdown your computer. The value is ranged between 10 and 90%. It is unavailable to be set lower than 10% or higher than 90%.

 UPS application must meet Window NT or above. Windows 2000 or Windows XP are recommended.

8. Update

Whenever the above settings are modified, click  to update.

10. Restore

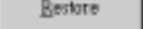
Click  to abort all the changes you made so far and restore your last settings.

11. Default

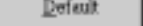
Click  to change all values to their default settings.

Cameras

Double-click  **Cameras** and choose the camera you want to configure.

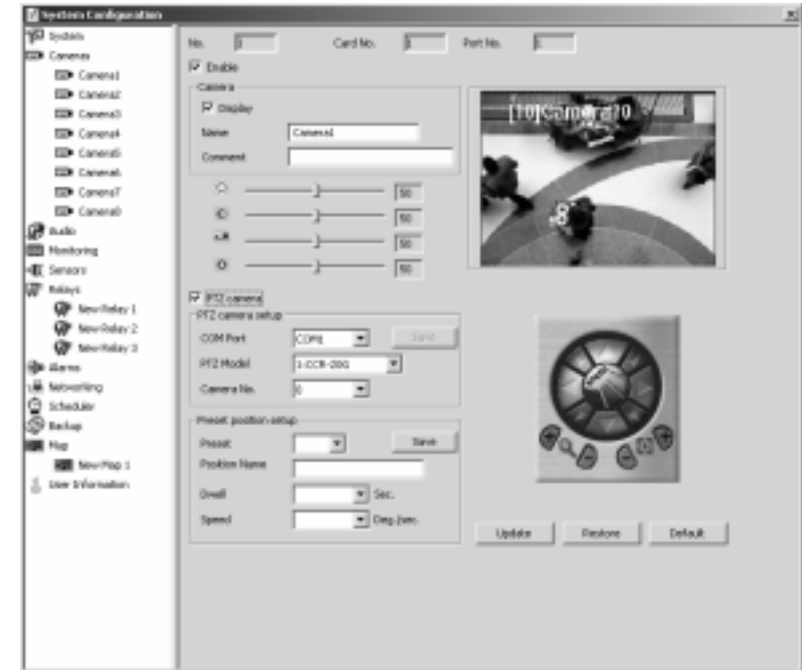

1. Camera ID

In the **No.** field, you can see the camera number you pick out from the left list.

2. Card No. / Port No.:

This section indicates the card number and the BNC connector number that this camera is connected to. It is configured by the system automatically and you cannot change otherwise.

3. Enable

Check **Enable** to enable this camera for monitoring. If a camera is not enabled, the image from this camera will show as Figure 1 (gray scale) on the screen. This camera's sign in the menu will change to .



If a camera input is not physically connected to a camera, you need to de-select Enable, or the system will not reach its best performance.

4. Camera

Display:

Check **Display** to display the image from this camera on the screen. If you check **Enable** without checking **Display**, the image from this camera will show as Figure 2 (color) on the screen. Although the image is not shown on the screen, this camera is still performing **Record When Motion Detected**, **Record When Start Monitoring**, or **Don't Record**, depending on which one you chose in the  **Monitoring** section of the System Configuration.

Name:

In the **Name** field, you can set the name for the camera.

Comment:

This field allows you to add any remarks you have for this camera. Any comment left can serve as a reminder for system manager.

Image Properties:

You may set the following properties for the image of this camera.





 brightness  contrast  color  saturation

Figure 1.

Gray-scale image

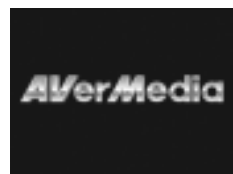
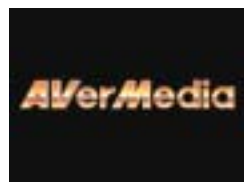

Figure 2.

Color image



Settings for the image properties are configured for the designated card, which may also connect to other cameras. That means, the settings you make for this camera will apply to other cameras that connect to the same card.



The adjustment of image properties will result in inefficiency as the video format is set to be PAL for the unsupported hardware temporarily

5. PTZ Camera

PTZ Camera Setup

- Select a **Com Port** where PTZ camera connector connected and the **PTZ Model** you use (refer to your PTZ camera spec.) by the pull-down lists. And click **Set** to place your setting.
- To control PTZ camera with server's camera by entering **PTZ Camera ID** at the range of 2~225.

Preset Position Setup

- Choose a position number by the pull-down list to set the monitoring position with the right side direction interface. Meanwhile the display you adjust will be shown on the upside.
- Determine a **Position Name** for the position.
- During AutoPan, **Dwell** determines the time for the camera to stay (1~60 seconds) at one position before rotating to the next position.
- You can set the **Speed** (5~255 deg/s) with which the camera rotates from its current position to the next preset position.
- Click **Set** to involve into the setting.

6. Update

Click this button to update the setting.

7. Restore

Click this button to abort all the changes you made so far and restore your last settings.

8. Default

Click this button to change all values to their default settings.

 **Audio**

Click  **Audio** to enter the audio page as below.

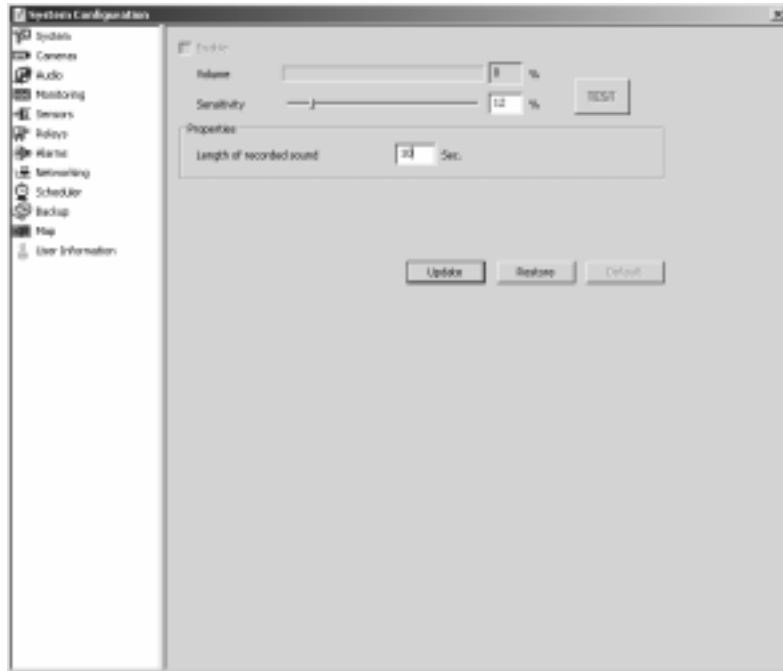

1. Enable

Check here to enable the automatic sound detection. The system will start recording upon detected volume greater than the sensitivity you set. **Note that this function only works while the system is recording videos.**

2. Detection Sensitivity

You can click  to test the volume of your current environment as a reference when adjusting the sensitivity. The system defaults the sensitivity to 30%.

3. Properties

You can set the length of time for the system to continue recording the audio once activated. The system defaults to 5 seconds. The length of time you set determines the size of the .WAV file. (1 second long roughly takes up 8K of space.) The .WAV file format is PCM 8KHz, 16bit, mono. **To playback the audio files, you need**

to go to  Log Viewer.

4. Update

Click this button to update the setting.

5. Restore

Click  to abort all the changes you made so far and restore your last settings.

6. Default

Click  to change all values to their default settings.

Monitoring

In this section you can configure how the cameras perform monitoring/recording and the related properties. Double-click on **Monitoring** and choose the camera you want to configure.



1. Motion Detection

Sensitivity:

In this area, you can adjust the motion detection sensitivity from 0 to 100 (system default: 90). The higher the value is, the better the sensitivity the system can detect.

Record with Time Stamp:

You can also add time information on the recorded video by checking **Record with time stamp** and choose the color of the time display.

Beep upon detected motion:

By checking **Beep upon detected motion**, you can enable the alarm to start beeping once motion detected. You can do an instant test it by clicking  and the following two signs represent different situations.



Motion detected in the detecting area



No motion detected in the detecting area

2. Recording

You can choose the suitable recording mode among these three:

Record when start monitoring:

The system starts recording once the monitoring starts.

Record when motion detected:

The system starts recording only when motion is detected, and continues recording for 1~120 (user-defined) seconds after the motion stops. The user-defined length of time (default to 1 second) is set in the Stop recording after sec. section.)

Don't record:

The system doesn't record no matter what happens.

3. Quality

This section allows you to choose the compressed program and adjust the image quality from 0 to 100 (default 50). The higher the value is, the lower the compression ratio gets, and the larger disk space is required. **You can also decide the recorded file size by changing the compression ratio.** If you select **Fast Recording** with MJPEG format (lower compression ratio), the system record faster, and therefore, the file size is bigger. On the contrary, if you select **High Compression Ratio** with MPEG4, the recorded file size will be smaller for they are highly compressed.

4. Motion Detection Mask

Mask

Mask a specific area to leave the rest area for the motion detection.

- First check **Mask** in the **Enable** field to edit the mask area.
- Check **Show Mask** to make masked area visible.
- To add or cut any masked areas, simply click **Add** or **Cut**, and then draw the area you want to add to or cut from the masked area. To clear all masked areas, click **Clear**. And click **Invert** to invert the masked areas into unmasked ones and vice versa.
- Choose a mask color out of from red, green, and blue.

Shield

To enable **Shield** provides you to protect some private areas from the entire surveillance control into a black shield, ex: a fitting room in a department store.

- First check **Shield** in the **Enable** field to edit the shield area.
- Refer to **Mask** step C.

5. Edit

Click on either the radio button for mask or shield to specify the working area by **Add/ Cut/ Invert/ Clear** in **Motion Detection Mask** field.

6. Update

Click this button to update the setting.

7. Restore

Click this button to abort all the changes you made so far and restore your last settings.



8. Default

Click this button to change all values to their default settings.

9. Start/ Stop Monitoring

After the settings are placed completely, click on the button  to activate the functions above when you are back to the main screen.

Sensors

Double-click on  **Sensors** to list the sensors already been configured. **Right-click the mouse on  Sensors to add a new sensor.** Click any desired sensor to enter the setup screen of that sensor.

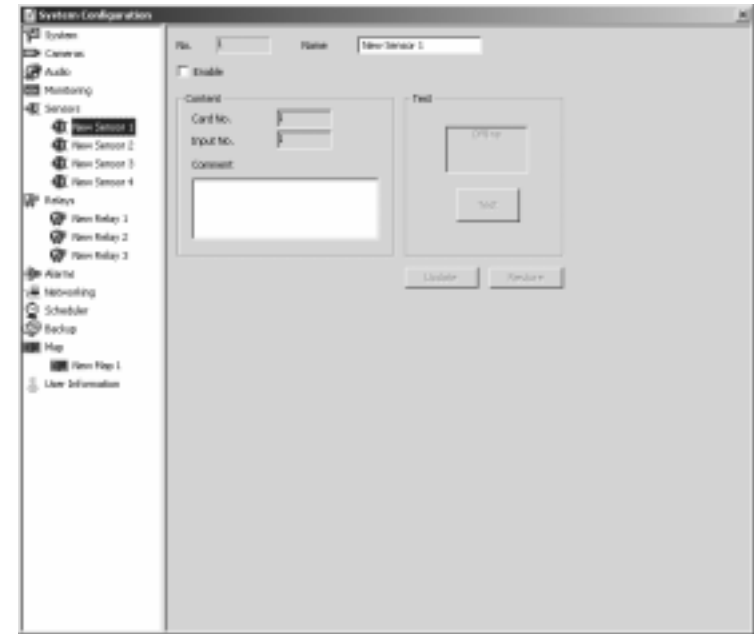

1. Sensor ID

In the **No.** field, you can see the sensor number. In the **Name** field, you can set the name for the sensor.

2. Content

Since each card can connect to one external I/O Box, and each I/O box supports 4 sensor inputs, you can easily determine the **Card No.** and **Input No.** as to where this sensor is connected. In the **Comment** field you can add any remarks you have for this sensor. Any comment left can serve as a reminder for the system manager.

3. Test

You can test the sensor immediately after you install it. Click  and if the test area turns red, it indicates the sensor is Closed/ON. If it turns green, it indicates the sensor is Open/Off.

4. Enable

Check **Enable** box to activate the previous setting.



5. Update

Click this button to update the setting.

6. Restore

Click **Restore** to abort all the changes you made so far and restore your last settings.

Relays

Double-click on  **Relays** to list the relays already been configured. **Right-click the mouse on  Relays to add a new relay.** Click any desired relay to enter the setup screen of that relay.



1. Relay ID

In the **No.** field, you can see the relay number. In the **Name** field, you can set the name for the relay.

2. Content

Since each card can connect to one External I/O Box, and each box supports 3 relay outputs, you can easily determine the **Card No.** and **Output No.** as to where this relay is connected.

In the **Comment** field you can add any remarks you have for this relay. Any comment you left can serve as a reminder for the system manager.

3. Test

You can test the relay immediately after you install it. Click , and if the test area turns red, it indicates the relay is ON/HIGH and generates an output signal. If it turns green, it indicates the relay is OFF/LOW.

4. Enable

Check **Enable** box to activate the previous setting.

5. Update



Click this button to update the setting.

6. Restore

Click  to abort all the changes you made so far and restore your last settings.

After the sensors and relays are configured, you can go to  **Alarm** to create alarms that will alert you when specified events take place.

Alarms

Double-click on  **Alarm** to list the alarm already been configured. **You may right-click the mouse on  Alarm to add a new alarm up to 64 alarms.** Click any desired alarm to enter the setup screen of that alarm.

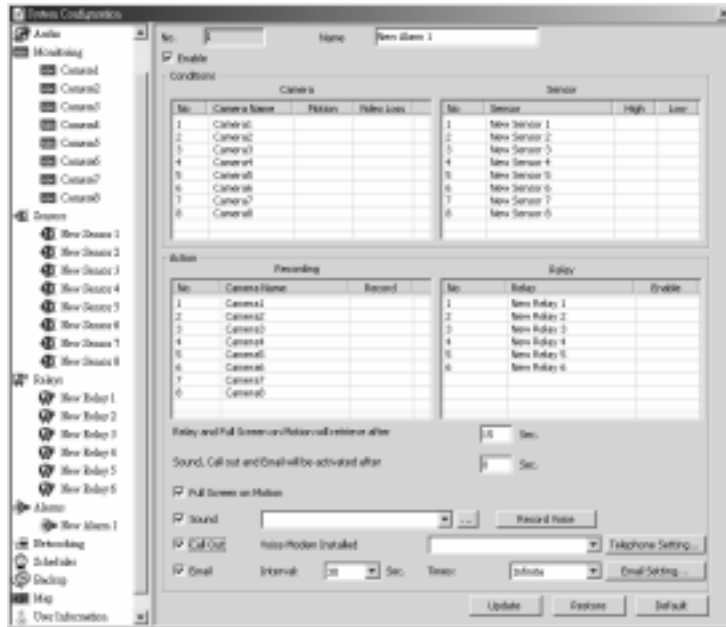

1. Alarm ID

In the **No.** field, you can see the alarm number. Also, you can set up the alarm name in the **Name** field.

2. Conditions

To set the event condition for cameras, check Motion field of the desired cameras to make their detected motion as an event to trigger the alarm. And check Video Loss field of the desired cameras to make their weak signal or video loss as events to trigger the alarm.

For sensors, select High (Closed/ON) or Low (Open/OFF) to be the event condition. **Note that for the alarm to be triggered, both event conditions for the camera and the sensor have to be met.**

3. Action

Recording & Relay Output:

To set actions, check the **Recording** column of the desired camera to start recording, and check the **Enabled** column of the desired relay to generate outputs when both the event conditions for cameras and sensors are met.

Relay and Full Screen on Motion retrieve

After an input is triggered, the output of relay and full screen on motion will revert to normal status after the time you set.

Sound, Call out and Email will be activated



The output ways you designate after an alarm is generated offer you to decide the deferment once an alarm is triggered.

Full Screen on Motion:

During surveillance, you can have the system to instantly pop up the image (1-camera display mode) that has motion detected for a user-defined length of time.

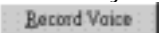
Sound Alarm:

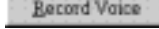
Check **Sound** to play a .WAV file when an alarm is triggered. You can assign the path of a specific .WAV file for the system play, or you can record a new .WAV file by clicking . To do so, follow the steps below:

- Click  and the recording utility pops up.
- Click  to start recording.
- Click  to stop recording.
- Save it as the .wav file.





Call Out:



If you have a voice modem installed, you can make the system to call out to landline/mobile phone or pager (maximum 5 sets in total) once an alarm is triggered. Follow the following instructions.

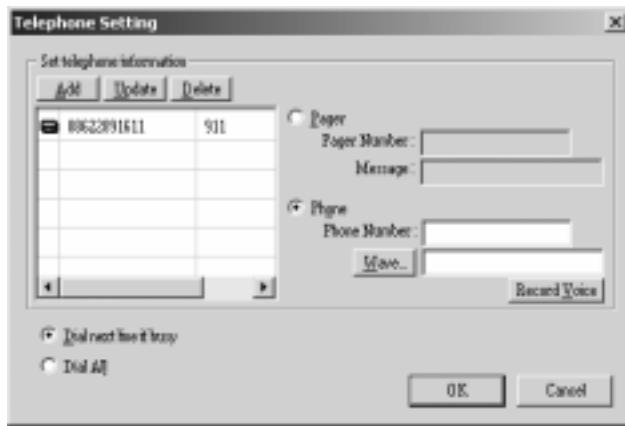



- A. Check **Call Out** to enable this function.
- B. Select a correct model for your voice modem from the drop-down menu of **Voice Modem Installed**.

- C. Click  to bring up the dialog box below to set up the telephone information. Here you should follow the steps described below to set the landline/mobile phone or the pager number.



- a. Select **Pager** or **Phone**.
- b. Key in the numbers for the landline/mobile phone or the pager, whichever you selected in step a. If you're setting up a pager info., you can compose a text message you wish to send to a pager by using numbers, *, and # in the Message field. If you're setting up a phone info., you can browse for a .WAV file by clicking  or create a new .WAV file by

clicking . After you complete the pager or phone information, click  to add this number to the table.

- c. Select **Dial next line if busy** or **Dial All**. In the former case, the system will dial the next number when the current one is busy. But if the call enters the voice mail of the mobile phone or gets picked up by an answering machine, the system will act as if the call-out is completed and won't dial the next line. Therefore, it is recommended for you to select the latter one, in which case the system will dial all numbers and send the warning message.
- d. The  /  buttons allow you to update/delete a pager or a landline/mobile phone number. To update, you need to first select the target number, key in the updated information, and then click . To delete, simply select the target number and click .

Email:

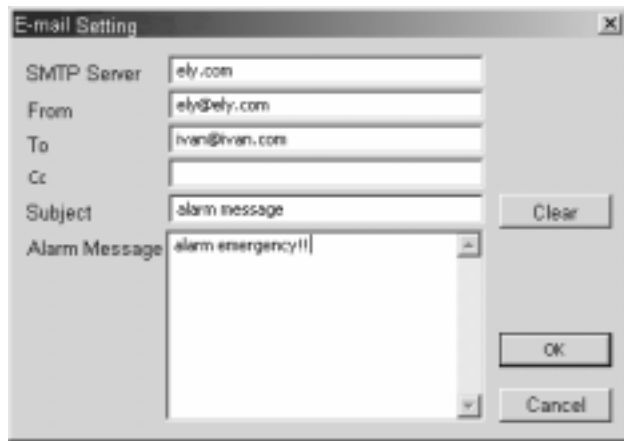

You can email alarm messages once an alarm is triggered. Follow the instructions below.

- A. Check **Email** to enable this function.
- B. Set the interval period and time to send the emergency e-mail.
- C. Click  to bring up the dialog box below to set up the email information.



Provide information for each field.

- SMTP Server: The domain name of your mail server or IP address. (eg. avers.com.tw)
- From: The sender's email address.
- To: The receiver's email address. Use ";" (semicolon) to separate each email address.
- Cc: The email address to which you want to send a copy.
- Subject: The subject of this alarm message.
- Alarm Message: The content of this email message.

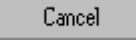
D. You can click  to clear all the inputs. Click  to save the email settings or click  to exit the dialog box without saving.

4. Restore

Click  to abort all the changes you made so far and restore your last settings.

Networking

Click  **Networking** to enter the networking setup page.

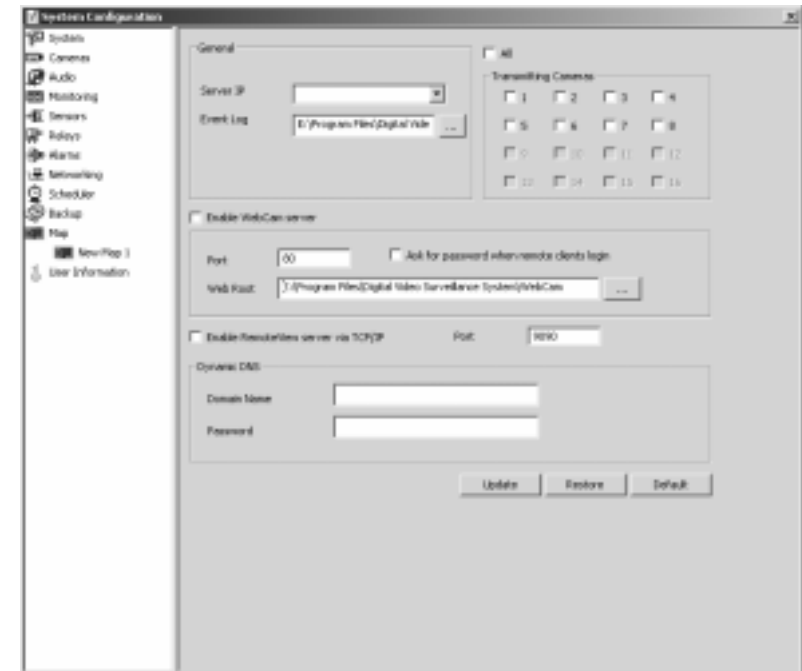

1. General

Server IP:

In this field, enter the IP address of the server for remote clients to access. Or you can choose from the drop-down menu where lists all the available IP for your computer.

Event Log:

This file, "**history.log**" keeps a record of all IP addresses of the client's computer during a remote transmission. You can click  to change its location.

Transmitting Cameras

Here you can select cameras allowed for remote monitoring.

2. Enable WebCam Server

Check here to enable WebCam Server for remote monitoring.

Port:

Set the port no. (default 80) for remote transmission.

Ask for password when remote clients login:

Check here if you need remote clients to provide passwords when they login the WebCam server.

Web Root:

In this field, you need to browse for the path where the WebCam home page is stored. When the remote client login the WebCam server, it will link to the WebCam home page from this path.

 **The WebCam server doesn't work under servers with IIS (Internet Information Service) installed.**

3. Enable Remote View server (Multicast server) via TCP/IP

If you want to transmit images for remote surveillance via TCP/IP, first check the checkbox to enable this function. Determine a port in **Port** box to connect client to a server with TCP port (default 9090). In addition, a firewall NAT function should be configured to enable the mutual transmission.

The following is the detailed illustration to configure the connection:

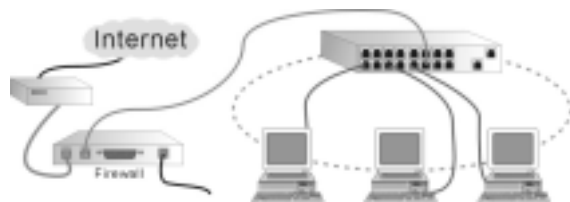

4. Dynamic DNS

In case a dynamic server is severed, please register a domain name with the IP address: ddns.avers.com.tw on line. Refer to **Appendix B** for the further information.

Domain Name & Password

Enter the domain name and password given in the process of registering a domain name or obtain them by asking network administrator.

5. Update

Whenever the above settings are modified, click  to update.

6. Restore

Click  to abort all the changes you made so far and restore your last settings.

7. Default







Click  to change all values to their default settings.

Scheduler

Click  **Scheduler** to enter the setup page for scheduler. You can schedule for monitoring, recording, or enabling network server by date or by weekday. Depending on your needs, after you set all the schedules, you can only enable the ones you currently need and disable the rest, which might be used later.



1. Enable



Check this to enable a schedule. Note that you still need to click  after you enable a schedule. Enabled schedules to monitor/record/enable network server are shown in  /  / , whereas disabled schedules are shown in  /  / .

2. Schedule Recording



You can choose to set the schedule by date or by weekday by selecting **By Date** or **By Weekday**.

By Date:

If you set the schedule by date, you can key in the date directly or choose from the drop-down menu and click  to add it to the  column. You can set multiple dates (max 60 days) for a single task. To take off a date from the column, click on the date you wish to delete and press [Delete] or [Backspace] on the keyboard.

By Weekday:

If you set the schedule by weekday, directly choose any day in a week. Multiple days for a single task are also acceptable.

 **You can only set future dates to for a schedule. Dates in the past are not acceptable.**

3. Time

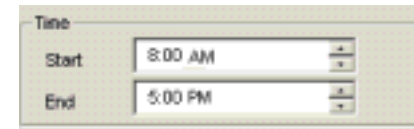



You can key in the start and ending time for the task in the following order: hour, minute, and AM/PM. Or use the up/down button to adjust the time. **The start time must be earlier than the ending time.** That means you can't span the time to the next day. To schedule a task that covers more than 1 day, you need to separate it into 2 or more schedules for the same task.

4. Task



Here you can select the task you're scheduling for.



Monitor

If you select **Monitor**, the system will activate this button  on the main menu when the scheduled time is due. The system will act according to the recording mode set in the  **Monitoring** section. Meanwhile, the system will also monitor the event conditions you set in the  **Alarm** section for the cameras and sensors and trigger the alarm accordingly.

Record

If you select **Record** as the task, the system will have the chosen cameras to start recording at the scheduled time. The task you set here enjoys higher priority than the recording mode you set for each camera. That means, even if you have set the camera to **Record when motion detected** or **Don't record** in the  **Monitoring** section, the camera will still start recording at the scheduled time.

Enable Network Server

When this is selected to be the task, the system will load network server  based on your settings in the  **Networking** section and start the remote monitoring for transmitting cameras.

Alarm

If Alarm box is checked, the Alarm will execute according to the **Alarm** section you plan as long as the **Time** is due. To exercise the prior privilege of **Scheduler**, the **Alarm** will perform by the scheduled time even though it is not enabled in **Alarm** section of System Configuration.



If the time of the schedule you set for a task overlaps with the time of an existing schedule for the same task, the system will give you a warning message below. In short, the time of 2 schedules for the same task cannot overlap.

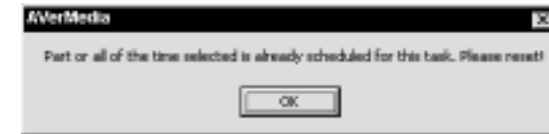

5. Cameras

When you select **Record** or **Alarm** to be the task, you need to select the recording cameras here.

6. Comment

Put your remarks here as a reminder of any schedule.

7. Add

Click  to add a new schedule to the table after all the necessary information is filled in this page.

8. Delete

You can select any task you want to remove from the table and click .

9. Update

To update a schedule, select it from the table, revise the information, and then click  to verify.

10. Restore

Click  to abort all the changes made so far for a schedule and restore its last settings.

11. Table

This table lists all the schedules you have set. You can arrange the order of the schedules by clicking different buttons.

Click  to view all the scheduled tasks.

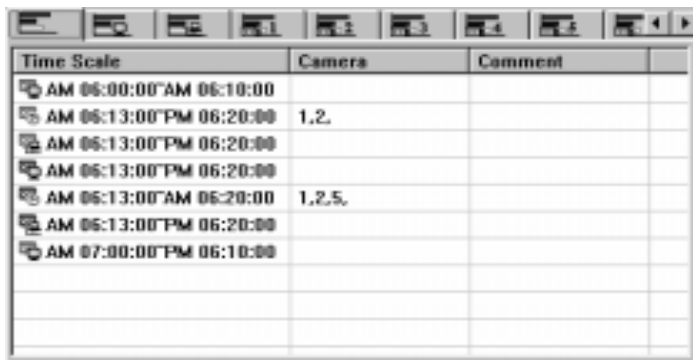

Time Scale	Camera	Comment
AM 06:00:00~AM 06:10:00		
AM 06:13:00~PM 06:20:00	1,2.	
AM 06:13:00~PM 06:20:00		
AM 06:13:00~PM 06:20:00		
AM 06:13:00~AM 06:20:00	1,2,5.	
AM 06:13:00~PM 06:20:00		
AM 07:00:00~PM 06:10:00		

Click  to view all schedules for the task **Monitor**.

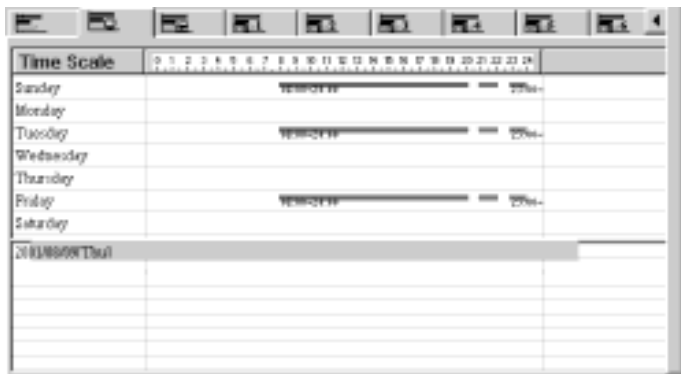

Time Scale	0	1	2	3	4	5	6	7	8	9	10	11	12	13	14	15	16	17	18	19	20	21	22	23	24
Sunday																									
Monday																									
Tuesday																									
Wednesday																									
Thursday																									
Friday																									
Saturday																									
2016/08/21(Sat)																									

Click  to view each camera's schedules for the task **Record**.



Time Scale	0	1	2	3	4	5	6	7	8	9	10	11	12	13	14	15	16	17	18	19	20	21	22	23	24
Sunday																									
Monday																									
Tuesday																									
Wednesday																									
Thursday																									
Friday																									
Saturday																									
2016/08/21(Sat)																									

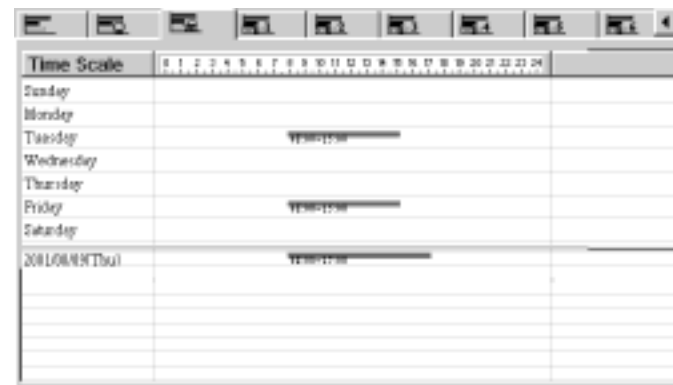

Click  to view all schedules for the task **Enable Network Server**.



Time Scale	0	1	2	3	4	5	6	7	8	9	10	11	12	13	14	15	16	17	18	19	20	21	22	23	24
Sunday																									
Monday																									
Tuesday																									
Wednesday																									
Thursday																									
Friday																									
Saturday																									
2016/08/21(Sat)																									

 **Backup**

Double-click on  **Backup** to view two backup methods:

 **Manual Backup** and  **Schedule Backup**. Click either to enter the setup page for each backup method.

 **Manual Backup**

Click  to enter the setup page for manual backup.



1. Operation

There are three ways to backup your files:



Move:

Simply move files from their original folders to the destination folders you assigned in the **Location** field.

Copy:

Copy files to the destination you assigned in the **Location** field.

Delete all. Don't make copies.:

Simply delete all the files and leave no copies.

2. Device

Select your backup device (CD-R or Hard Disk/ZIP) here. If you choose CD-R, you need to specify the size of the CD-R, which will limit the size of each recording folders. After finishing the backup, run a CD-R burning program, such as Nero Burning, to burn the folders on CDs.

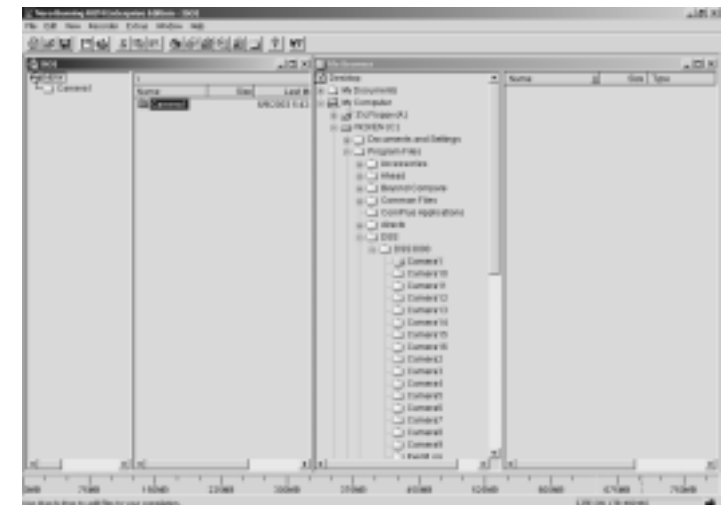

3. From/ To

Here you need to set the start and ending date/time.

4. Cameras

Select the cameras whose files you want to backup. Check **Audio** to backup the recorded sound files.

5. Statistic

Click  to calculate the number of the selected files and their total size.

6. Backup

Click  to start the manual backup.

Schedule Backup

Click  to enter the setup page for schedule backup. Depending on your needs, after you set all the schedules, you can only enable the ones you currently need and disable the rest, which might be used later.

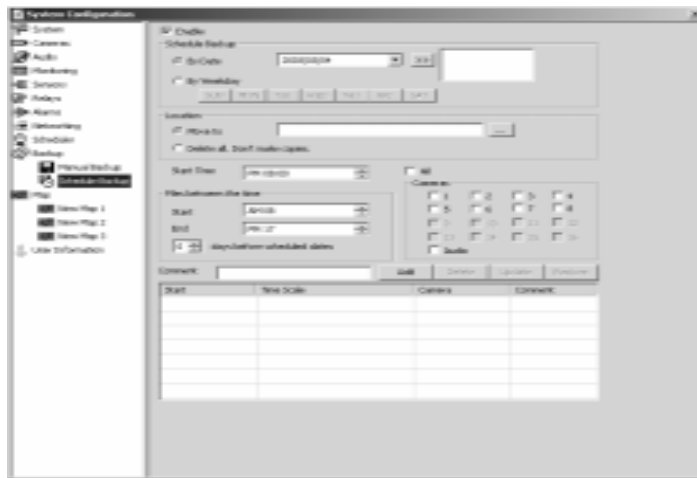

1. Enable

Check this to enable a schedule for a backup. You still need to click  after you check to enable a schedule.

2. Schedule Backup



You can set the schedule backup by date or by weekday by selecting **By Date** or **By Weekday**.

By Date:

If you set the schedule backup by date, you can key in the date directly or choose from the drop-down menu and click  to

add it to the  column. **You can set multiple dates (max 60 days) for a backup schedule.** To take off a date from the column, click on the date you wish to delete and press [Delete] or [Backspace] on the keyboard.

By Weekday:

If you set the schedule backup by weekday, directly choose any day in a week. Multiple days for a backup schedule are also acceptable.

3. Location

You need to specify a destination here to move the backup files if you check **Move To**. If you check **Delete all. Don't make copies.**, the system will delete all the files and leave no copies.

4. Start Time

Set the start time of the backup schedule.

5. Files between the time

Start & End:

The system will look for files of the selected cameras between the **Start** and **End** time you set here. Adjust the time by hour/minute and AM/PM with the up/down button. **Note that the start time cannot be later than the ending time.** That

means you can't span the time to the next day. To backup files that cover more than 1 day, you need to separate the files into 2 or more backup schedules.

Days before scheduled dates:

You can also backup files X days (user-defined) before the scheduled dates you put in the **Schedule Backup** section.

Example:

If you schedule for 2003/05/03 and 2003/05/06, and you enter "2" in the number of days before scheduled dates field, then the system will backup on 2003/05/01 and 2003/05/04. So if you want the system to perform backup on the exact dates you scheduled, simply input "0" as the number of days before scheduled dates.

6. Camera

Select the cameras whose files you want to backup. Check **Audio** to backup the sound files from the selected cameras.

7. Comment

Put your remarks here to serve as a reminder of a schedule.

8. Add

After all the necessary information is filled in this page, click  to add a new schedule for a certain task to the table. All the schedules you have set will show up in the following table.

9. Delete

Select the schedule you want to remove from the table and click  to delete.

10. Update



Select the schedule you want to update, revise the information, and then click  to verify the update.

11. Restore

Click  to abort all the changes made so far for a schedule and restore its last settings.

 E-Map

Here provides a completely configured map where all cameras, sensors, and relays are set.

Double-click on  **E-Map** to list the e-maps already been configured. **Right-click the mouse on  E-Map to add a new e-map.** Click any desired e-maps to enter the setup screen of that e-map.

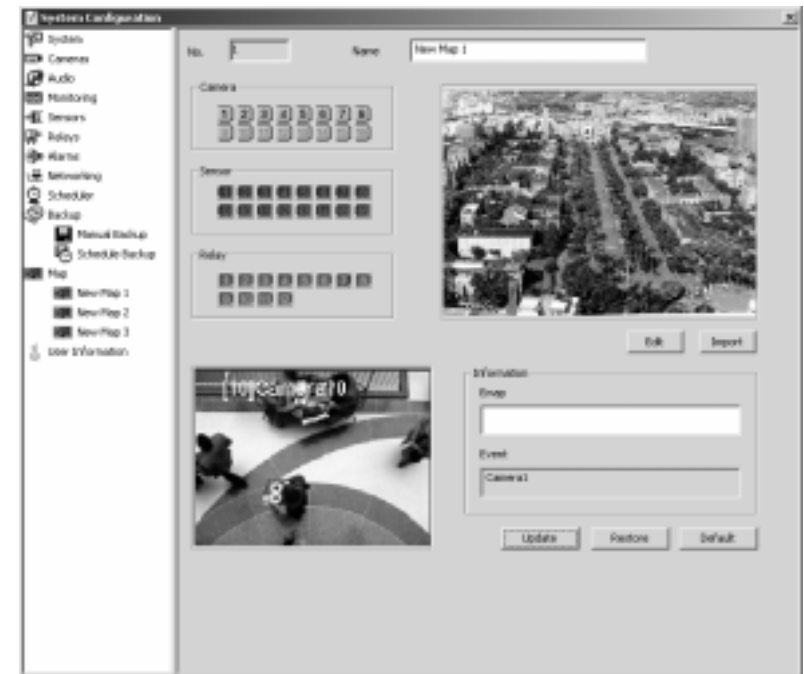

1. First define the name of e-map.

2. Configure e-map

Import

If an image of map (bmp./jpg. formats are supported) has existed, click **Import** button to input the image which will be shown on the right side screen.

Edit

If you don't have an image of map in hand or need to modify the image, click **Edit** button to bring out the bmp. or jpg. programs to create an one or revise it.

3. Arrange Cameras, Sensors, and Relays

To add a new event, drag the button of Camera, Sensor, or Relay in the left side field and drop in the desired position of the map. The buttons not be set up will be disabled. To delete, drag and drop it in any positions out of the map. Whichever camera you click on, the monitoring status of which will be displayed in the left bottom field.

4. Information

Put in some information for each event to be reference during operation. Each edit box is limited in 32 bytes.

5. Click **Update** button to save your current setup.

6. Click **Restore** button to recover the previous setup.

7. Click **Default** button to change the setup to default settings.

Users Information

Click  to enter the setup page for user information.

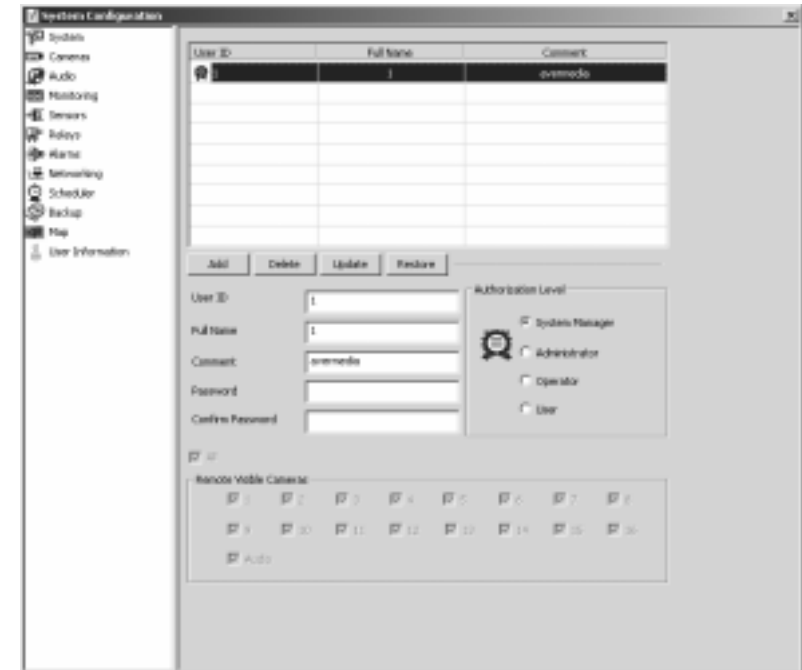

1. Add New Users

To add a new user, first fill the **User ID**, **Full Name**, **Comment**, **Password**, **Confirm Password**, and **Authorization Level** (*System Manager*, *Administrator*, *Operator* and *User*) fields. Next select the cameras that can be remotely viewed by this user and click .

2. Remote Visible Camera section

You need to select which cameras and whether the audio files are accessible remotely for the user you are going to add. You can check **All Cameras** to select all, including the audio.

3. Delete

To delete a user, select that user and click **Delete**.

4. Update

You can update a user's information by selecting that user, key in the latest information, and click **Update**.

5. Restore





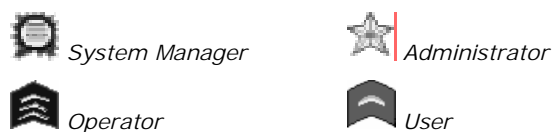

During the modification of a user's information, you can click **Restore** to abort all the changes made so far and restore the last settings.



















6. Authorization Level











The EYES Pro/MP2016/MP3000/MP5000 surveillance system uses the following 4 authorization levels to classify users through password control.



You need to enter your ID and password to identify your authorization level when you login/logout, stop/start monitoring, or load/stop network server. The table below illustrates the privilege of users from different levels when accessing each function.

4-Level User Control	 System Manager	 Admin.	 Oper.	 User
Function / Setup				
 Start / Stop Monitoring	V	V	V	
 Start / Stop Audio Recording	V	V		

 Load / Stop Network Server	V	V	V	
 System Configuration	V	V		
 System	V	V		
 Cameras	V	V		
 Audio	V	V		
 Monitoring	V	V		
 Sensor	V	V		
 Relays	V	V		
 Alarms	V	V		
 Networking	V	V		
 Scheduler	V	V		
 Backup	V	V		
 E-Map	V	V	V	V
 User Information	V			
 Log Viewer	V	V		
 PTZ Controller	V	V	V	
 1-Camera Display	V	V	V	V
 2-Camera Display	V	V	V	V
 4-Camera Display	V	V	V	V

 9-Camera Display	V	V	V	V
 12-Camera Display	V	V	V	V
 16-Camera Display	V	V	V	V
 1-Camera Enlarged Display	V	V	V	V
 6-Camera Display	V	V	V	V
 8-Camera Display	V	V	V	V
 10-Camera Display	V	V	V	V
 13-Camera Display	V	V	V	V
 Full Screen Display	V	V	V	V
 Start / Stop AutoScan	V	V	V	V
 1. 2. 3. ... 16. Focus Camera	V	V	V	V

The *System Manager* is allowed to operate all functions and to configure all settings for the system. The *Administrator* possesses all the rights as the *System Manager* except to set the  **User Information** section of System Configuration. *Operator* has no rights to enter System Configuration. The *User* can only view the monitoring screen.

4.2 System Operation





This section describes how to operate EYES Pro/MP2016/MP3000/MP5000 surveillance system.



Product Models



4 EYES Pro/MP3004/MP5004

4 EYES Pro/MP3004/MP5004 provides  1-Camera Display,  1-Camera Enlarged Display,  4-Camera Display,  Full-Screen Display and  Start/Stop AutoScan.



8 EYES Pro/MP3008/MP5008

8 EYES Pro/MP3008/MP5008 provides 1-Camera Display, 1-Camera Enlarged Display, 4-Camera Display, 6-Camera Display, 8-Camera Display, 9-Camera Display, Full-Screen Display and Start/Stop AutoScan.



16 EYES Pro/MP2016/MP3016/MP5016

16 EYES Pro/MP2016/MP3016/MP5016 provides 1-Camera Display, 1-Camera Enlarged Display, 4-Camera Display, 6-Camera Display, 8-Camera Display, 9-Camera Display, 10-Camera Display, 12-Camera Display, 13-Camera Display, 16-Camera Display, Full-Screen Display and Start/Stop AutoScan.

Display Modes

Each display mode is illustrated in the grids below. Numbers in the grids represent the camera number.



1-Camera Display

Click this button to view image from a single camera. If you have more than one camera installed, you can click any number **1. 2. 3. ... 16.** (Focus Camera) to switch to a specific camera.



4-Camera Display

Click this button to split the screen into a 4-camera display. The screen will first display cameras 1~4. Click it again changes the display to cameras 5~8. Further clicking will change the display to cameras 9~12, 13~16, 1~4, and so on. See the following sequence.

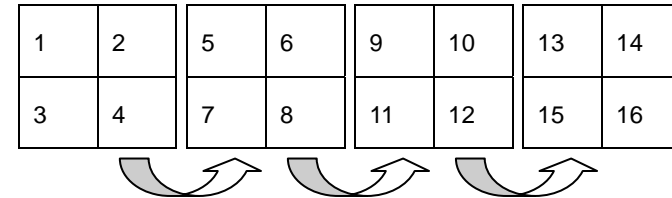

9-Camera Display

Click this button to split the screen into a 9-camera display. The screen will first display the camera 1~9. Click it again changes the display to camera 5~13. Further clicking will change the display to cameras 9~1, 13~5, 1~9, and so on. See the following sequence.

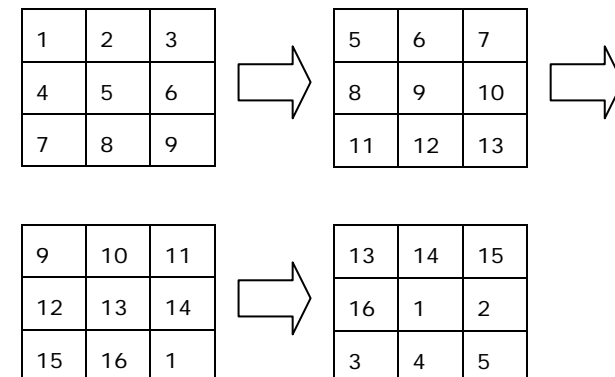



12-Camera Display

Click this button to split the screen into a 12-camera display. The screen will first display the camera 1~12. Click it again changes the display to camera 5~16. Further clicking will change the display to cameras 9~4, 13~8, 1~12, and so on. See the following sequence.

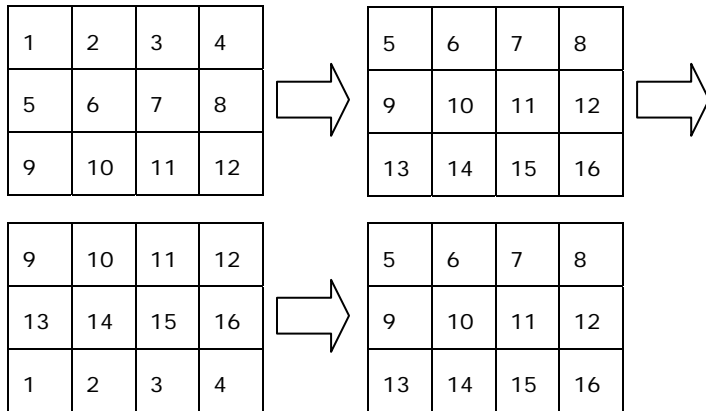

16-Camera Display

Click this button to split the screen into a 16-camera display.

1	2	3	4
5	6	7	8
9	10	11	12
13	14	15	16



1-Camera Enlarged Display

Click this button to split the screen into a 1-camera enlarged display. Further clicking will change the enlarged image to the next camera.

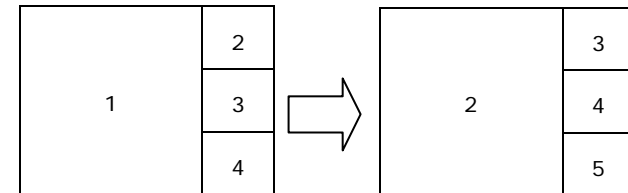

6/8/10/13-Camera Display

Click this button to split the screen into a 6/8/10/13-camera display. Further clicking will change the enlarged image to the next camera.



Full Screen Display

Click this button to switch to full screen from all display modes.





Start / Stop AutoScan

AutoScan allows you to view each camera image in numerical sequence under 1-Cam Display mode. To enable this function, you need to go to the **System** section of System Configuration to check AutoScan and define the scan interval. After this function is enabled, return to the main menu and click this button to start/stop the AutoScan function. During AutoScan, you can click **1. 2. 3. ... 16.** Focus Camera to jump to any camera.

1. 2. 3. ... 16. Focus Camera

The number on each button represents the camera number. These buttons show the status (enabled / disabled) of each camera. Under all display modes, when you click any of the camera number from the focus camera buttons, that particular camera will be switched to the first camera in display.

 Start / Stop Monitoring

Click  to start/stop monitoring. If the system is recording videos from a camera, a red triangle will appear in the upper left corner of the image frame. If you set this camera image to be recorded upon detected motion, a green triangle will show up together with the red one when you click  to start monitoring.

While monitoring, the system simultaneously monitors the cameras and sensors for the conditions you set in the  **Alarms** section of System Configuration. Once both conditions for cameras and sensors are met, the corresponding alarm will be triggered.

 Start / Stop Audio Recording







Click this button to start/stop recording audio. Here it shows the volume of the current environment. According to the settings in the  **Audio** section of System Configuration, once the detected volume is greater than the sensitivity, the system will start to record the sound for a user-defined length of time. It will then save the .WAV file to the path you specified. **Note that the auto sound detection only works while the system is recording images from the camera.**

 E-Map

After the configuring in the  **E-Map** section of System Configuration, click this button to view the e-maps.



1. Chose a map to view by clicking the map button .
2. **Check out Cameras, Sensors, Relays on the map**
Focus on the desired event by clicking on the event button on the map.
3. **Monitoring Cameras, Sensors, and Relays**
If any event is focused, the relative information will present in the information field; otherwise, you can monitor the status of the camera in the right upper window. The different colors of the icons on the map window will turn to different flashing colors accounting for as follows:

Icon	Color	Status	Icon	Color	Status
	Yellow	Normal	 Sensor	Yellow	Normal
	Blue	Video Loss	 Sensor	Red	Activated
	Green	Motion Detection	 Relay	Yellow	Normal
			 Relay	Red	Activated

4. Click **Exit** to leave for main menu.



Load / Close Network Server

Click this button to load/close the network server, which allows for remote surveillance (Web Cam/RemoteManager). You will need to provide a password to identify your authorization level before the system actually loads/closes the network server. To configure the network settings, go to the  **Networking** section of System Configuration.



System Configuration

Refer to section 4.1 - System Configuration.









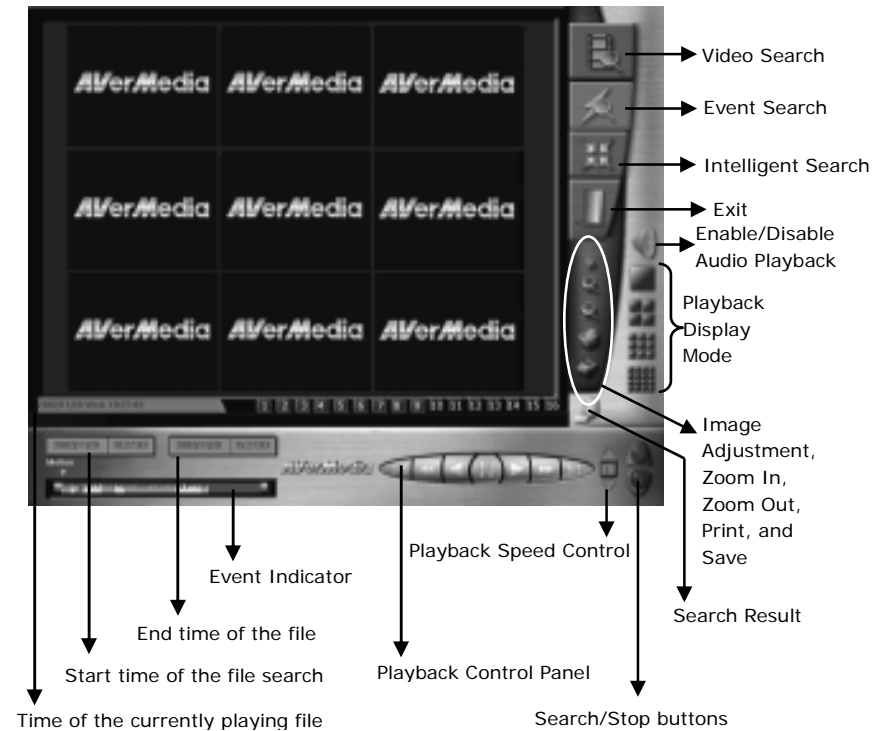

Log Viewer

Log viewer allows you to playback log files from single channel as well as from 4/9/16 channels simultaneously. All the functions here will be introduced in operational order.

Click this button to enter the following log viewer page.



1. Select Display Mode

When you enter this page, first select the display mode by clicking  (1 Channel),  (4 Channels),  (9 Channels), and  (16 Channels). You can also click these buttons to switch display mode during playback. To switch to a specific camera, click    ...  to play videos of that camera.

2. Audio Playback

If you also want to play audio files, click  to enable audio playback.

3. Select Files to Play



Next you need to choose files that you want to playback.



A. Select Time

Click  to select the date & time for the start time (on the left) and end time (on the right) respectively. The system will instantly show video data that has motion (default event) detected during the specified time frame in the event indicator below.

B. Play

Click the  **Playback** button to play files from start to end. You can also manually drag the slide bar in the directly to  the frame you want to play and click the  **Playback** button. The lines in the event indicator represent time points where the specified event has taken place.



4. Playback Control

Once you start to playback videos, you can use the following function buttons during playback.

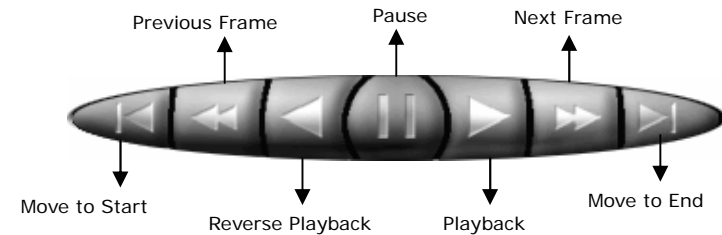

5. Playback Speed Control



You can click the up and down buttons from  to adjust the playback speed. You can choose from 8, 4, 2, 1, 1/2, 1/4, and 1/8 times of the normal speed.

6. Image Quality

Click  to adjust the image quality. You can adjust the brightness, contrast, color and saturation.

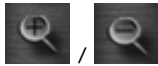

7. Zoom



Click  /  to zoom in/out the image.

8. Print & Save



During playback, you can click the  **Print** or  **Save** buttons to print or save the current image.



Note that every image you save with the format of bmp. provides the functions of anti-counterfeit and anti-destruction. You can access **Image Verify** from Programs to make verification for the saved images.





Video Search

Searches the recorded files shown in tree diagram by year/ month/ date/ hour/ minute/ second consequence.

To enable this function, complete the following tasks:

- Click **Video Search** and the **Video Table** searching list will pop up such as the following window:

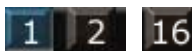

- Click  the camera no. button to select the camera no. which is switchable during searching.
- Select the required recorded file from the **Video Table** list and click **Close** to hide the window.
- Once the **Video Table** hides, the initial and end time and status of the chosen file will be shown on the left bottom of the window where the start and end time of the files and event indicator locate.
- Click  **Playback** button to display the recorded file. During playing, the indicator in event indicator will move with the display going and show the playing time in the field of the start time of the file.
- Click **Search Result** to pop up the previous **Video Table** searching list and take the steps above to review the recorded file.



Note that the searched peaks in Event indicator field in this section denote the time points of starting recording instead of the file positions. Therefore, a peak (not everyone) is likely to be displayed by clicking on a showed peak directly in Event indicator field.



Event Search

Searches the recorded files by the alarm condition and action within a specified period of time.

To make the function workable, complete the following steps:

- A. Click **Event Search** and the playback control panel will turn into the condition search panel as follows:



- B. Choose the camera display mode  (1, 4, 9, 16 ch) from playback display mode.
- C. Set up the initial and end time for searching in the time fields on the left bottom of the window.
- D. Choose the search condition as the specified condition to search the file from the condition search panel; Motion detections, video loss, sensor inputs, relay outputs, audio, system call out, alarm recording.
- E. Click **Search Result** to start searching and the coincident recorded files will be shown on the pop-up **Event Table** searching list.
- F. Click **Stop Search** to stop searching if necessary.

- G. Select the desired recorded files and click **OK** to hide **Event Table**. Meanwhile, the status of the files will be seen on event indicator and the playback control panel pops up to replace the condition search panel.
- H. Click  **Playback** button on the playback control panel, or, otherwise move the indicator on event indicator directly to display the files. During playing, the indicator will move with the display going and show the displaying time of the file in the field of the start time of the file.
- I. Click **Search Result** to pop up the previous **Event Table** searching list and take the steps above to review the recorded file.



Note that the searched purplish red peaks in Event indicator field denote the recorded files that can be displayed on clicking them. However, the other searched peaks with other colors indicate the generations by the selected events that can't be displayed on clicking them.



Intelligent Search

Searches the recorded files by **Mask Area** and **Search Interval** with a specified period of time.

To enable this function, complete the steps below:

- A. Click **Intelligent Search** and the playback control panel will be replaced by the search condition setting panel such as the following window:

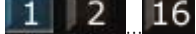

- B. Click  the camera no. button to select the camera no. which is switchable during searching.
- C. Set up the initial and end time for searching in the time fields.
- D. Determine a time value for **Search Interval**.
- E. Drag out a mask area with **Mask Area** and color box devices for the specified detecting area.
- F. Click **Search Result** to start searching and the coincidentally recorded files will show the searching list on pop-up **Intelligent Table**.

- G. Select the desired file and click **OK** to hide **Intelligent Table**. Meanwhile, the status of the file will be seen on Event indicator and the playback panel pops up to replace the search condition setting panel.
- H. Click  **Playback** on the playback control panel, or, otherwise move the indicator in event indicator directly to display the file. During playing, the indicator will move with the display going and show the displaying time of the file in the field of the start time of the file.
- I. Click **Search Result** to pop up the previous **Intelligent Table** searching list and take the steps above to review the recorded file.

9. Exit

Click the  **Exit** button to exit log viewer.



PTZ Controller

When you click this button, the PTZ control interface will pop up and allows you to control your PTZ cameras. Click this button again to hide this interface.

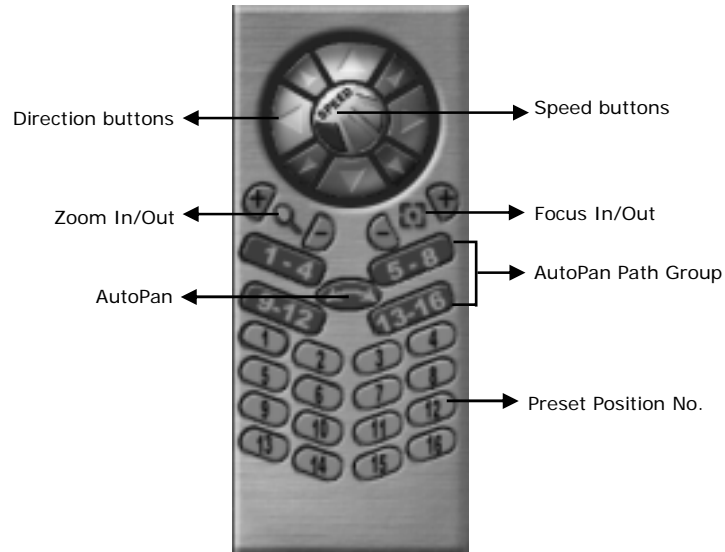

1. PTZ Control



Direction & Speed

You may click the buttons on the outer circle to adjust the camera's direction during surveillance. The inner circle contains buttons for 4 levels of PTZ rotating speed. Click on them to change the speed.



Focus

Press the + and - buttons any time during surveillance to increase/decrease the focal length to get a clearer image.



Zoom

Press the + and - buttons any time during surveillance to zoom in/out the object.



Preset Position No.

Anytime during the surveillance you can turn the camera to any desired position by directly clicking on buttons 1~16.



AutoPan Path Group

These buttons allow you to select the path of the AutoPan. For example, if you click **5-8** and then click the **AutoPan** button, the AutoPan will do a scan from preset position 5→6, 6→7, 7→8, 8→5, 5→6 until you click the **AutoPan** again.





AutoPan

You need to first choose the group of the AutoPan paths, and then click this button to run the AutoPan. If you don't choose a path before you click the **AutoPan** button, the following warning will show up.



The PTZ camera will run AutoPan based on your preset position settings. For example, if **1-4** is chosen and the Dwell/Speed of preset position 1 and 2 are 3 seconds/30° per second and 6 seconds/90° per second.

Therefore, once you click the  **AutoPan** button, the camera first turns at a speed of 30°/sec from its current position to position 1 and stays for 3 seconds, then from position 1 to 2 at a speed of 90°/sec and stays for 6 seconds. The camera continues to go around in such a fashion (2→3, 3→4, 4→1, 1→2,

 PTZ cameras of different makes can have different ways to run the AutoPan function and might differ from the above. Refer to the respective user's manual of the PTZ camera.

2. Exit PTZ Controller

Simply click  to exit from PTZ controller interface.

Status Monitoring

Alarm / Relay / Sensor Status

On the right side of the main surveillance window is a panel that shows alarm, relay and sensor status. Installed sensors are shown in bright color while not installed ones remain dark. Once a sensor is activated, the color will turn yellow. For relays, installed ones are shown in bright color and activated ones turn yellow color.



When an alarm is triggered, the  will turn red color. Double-clicking on this button will bring up the following dialog box.

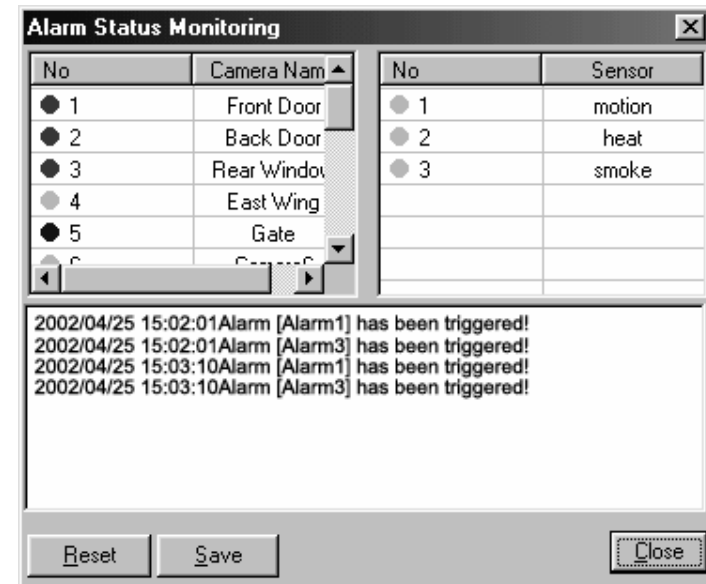

The red dot next to the camera/sensor number indicates that the event condition for this particular camera/sensor has been met. The green dot indicates no event occurs. And the blue dots means the video signal is too weak or the video cable has been disconnected (video loss.) The list below lists all events in time order.

You may click the **Reset** button to clear the triggered alarms including camera recording, siren or other relay outputs. However, this action requires a password to confirm your authorization level. Click the **Save** button to save all alarm records. Click the **Close** button to close the dialog box.

3.677GB, 62.8hrs **Hard Disk Status**

This area shows the remaining hard disk space and time (in hours) for video recording. When you double-click on this area, a dialog box that lists all recording-related events and disk space will pop up.

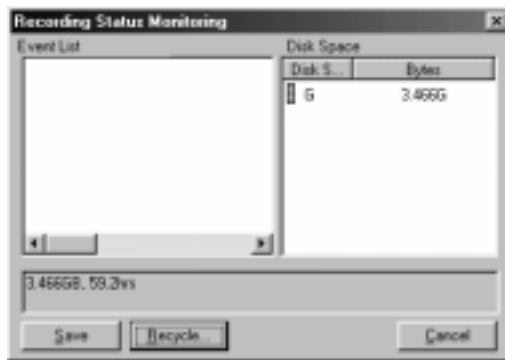

You can click the **Save** button to save the events. Or click the **Recycle** button for the system to check if the hard disk needs to start recycling. Click the **Cancel** button to exit.

18:00:58 RemoteManager server closed. **Network Status**

This area presents you the current network status. You can also click  in the upper-right corner of the main surveillance window to get a full list of network related events.

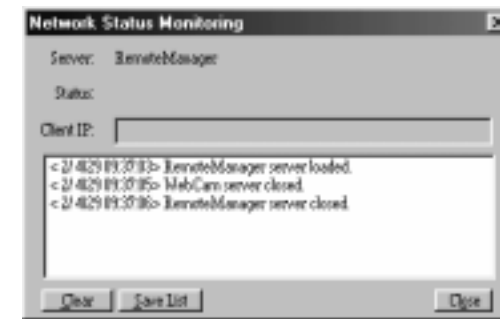

Note that  will flash in maroon color during data transmission.

04/15/02 (Monday) 18:01:38 **Date / Time**

Here shows the date and time.



Exit / Re-login EYES Pro/MP2016/MP3000/MP5000

When you want to exit or re-login the system, click  to enter the logout screen below:



Click  to stop monitoring and logout.

Click  to login the EYES Pro/MP2016/MP3000/MP5000 surveillance system as another user.

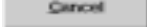
Click  to cancel the logout and go back to the surveillance window.

Click  to minimize the surveillance window.

Chapter 5 Using the WebCam

You can monitor images from the AVerMedia EYES Pro/MP2016/MP3000/MP5000 server using Internet Explorer browser. The AVerMedia EYES Pro/MP2016/MP3000/MP5000 system has built in HTTP protocol and web server services.



Note that WebCam function must be running in Internet Explorer with version 5.5 or above.

5.1 Enable WebCam

Before you start monitoring from the remote browser, verify that the AVerMedia EYES Pro/MP2016/MP3000/MP5000 server has finished the following settings.

1. IE setting

Access **Internet Options** setting from **Control Panel** as the following dialog.



- Select **Security** page to configure **Internet** and **Local internet** sectors respectively.

- b. Click **Custom Level** button to pup up the following dialog. Check **Enable** or **Prompt** radio button both in **Download signed ActiveX controls** and **Download unsigned ActiveX controls**.



2. Enable Web Cam (see Networking)

- Verify IP address.
- Select cameras to perform remote transmission.
- Check **Enable WebCam server**.
- Click the **Update** button and exit the dialog box.

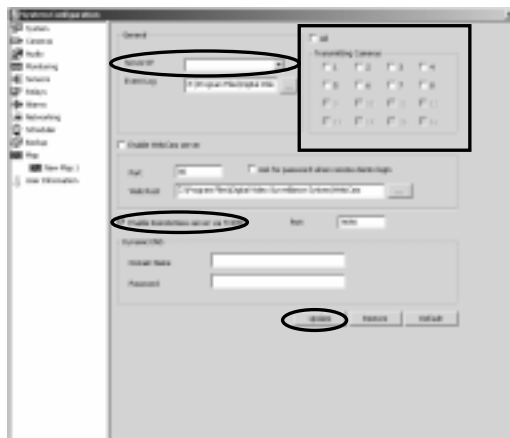

3. Load Network Server







Click  at the bottom of the main menu to enable the networking function.

5.2 Use the WebCam

You can browse the home page of WebCam with Microsoft IE to access desired server by key in the IP or domain name of which.



When you enter the home page, you can see the system defaults to 1-Camera display. You can click these buttons to change different numbers of split display:

-  1-Camera Display (640x480)
-  4-Camera Display (320x240)
-  6-Camera Display (320x240)
-  8-Camera Display (Enlarged: 480x360, Small: 160x120)
-  9-Camera Display (320x240)
-  10-Camera Display (Enlarged: 320x240, Small: 160x120)
-  16-Camera Display (160x120)

When the remote transmitting cameras are more than the split display

number, you can click **NEXT** to switch the screen to display the following cameras. For example, the server has assigned camera 1, 2, 3, 5, 7, 10, 13, and 16, in total 8 cameras for remote transmission.

If you select 4-Camera Display,

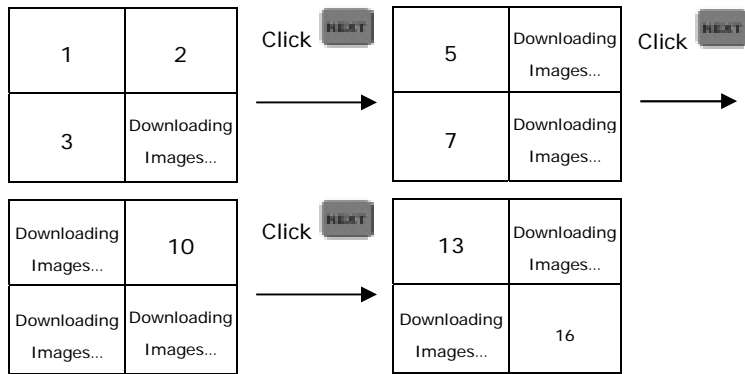

If you select 6-Camera Display,

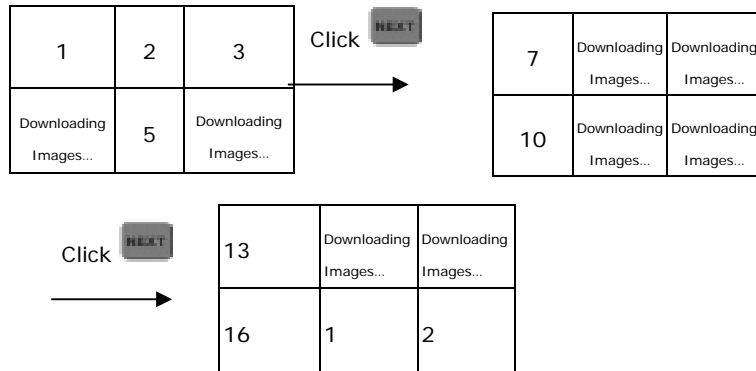

You can also change the display sequence by assigning different cameras to different channels. Click **SET** to select a channel from the drop down menu **Channel 1** in **Server Channel No.** corresponding to camera no. If the selected cameras are not remote viewable, then the image on the screen will not change.

Chapter 6 RemoteManager

6.1 Accessing RemoteManager

You need to install the remote surveillance program RemoteManager from the CD-ROM (See Chapter 3 - Software Installation.)

i Note that the operation system of Microsoft® Windows 2000 and XP are recommended for RemoteManager program.

The RemoteManager program allows you to manage the server from a workstation almost as if you were working from the server console. This will allow you to be able to configure the server from a remote location.

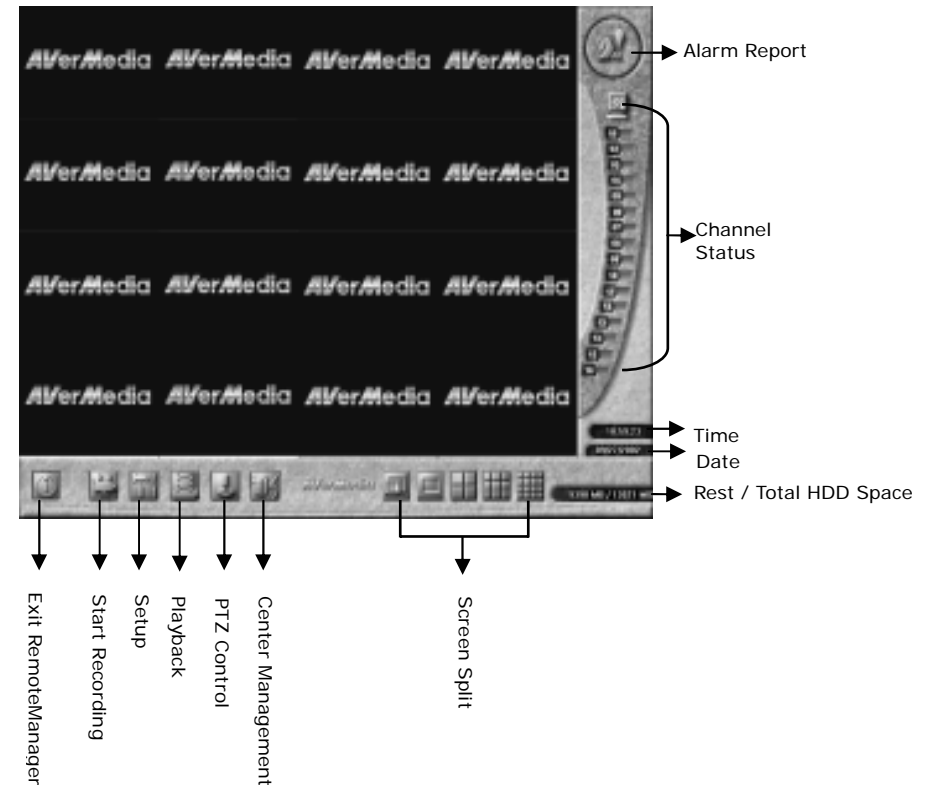

Login

Once you first start the program by clicking the shortcut of Remote Manager on your desktop, a Login dialog right side will prompt you to enter the user ID and password to access to the program. Note that only "root" is the acceptable user ID for the initial access. And a **User Management** window for permitting the beginning into the system will be seen. To set the setting of the permission, refer to the **6.3.1 Center Management** for the detailed description.









Alarm Report

The image will turn into red and be flashing once an alarm is triggered. An alarm message with the detailed alarm status will be seen after you click on it. It will help you control the situation of surveillance.



Channel Status

An area where the status of all the channels will be shown as the following description and is with a tip of channel's, server's, camera's names while your cursor points the button:

-  Dark Gray All Disabled
-  Flashing Pale Gray Video loss
-  Azure Normal and the image is displayed on the screen
-  Dull Blue Normal but the image had been disabled to display
-  Pink Red Recording and the image is displayed on the screen
-  Dark Red Recording but the image had been disabled to display

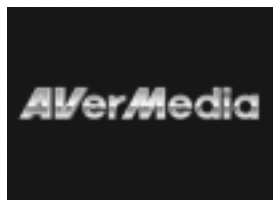

If a camera is not enabled, the image from this camera will show as the image above (gray scale) on the screen.

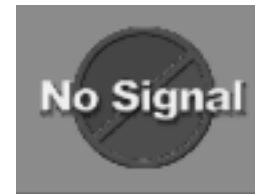

If a camera is disconnected to the server or the signal from the server is disconnected to the local camera, the image will show as above on the screen. The signal will be picked up at an interval of one minute until it is received.

Display Mode

Select a display mode to arrange the presentation of the screen.



Full Screen



1-Cam Display



4-Cam Display



9-Cam Display



12-Cam Display

No matter what channel mode you choose, you can assemble the channels as you wish by clicking **Channel Status**  to meet the amount of the mode. For example, if you choose 4-Cam display mode, you can click 4-Cam display (1,4, 8, 13), (3, 5, 7, 8), or other groups of the channels to meet the quantity of 4 channels mode.

6.2 Setup

6.2.1

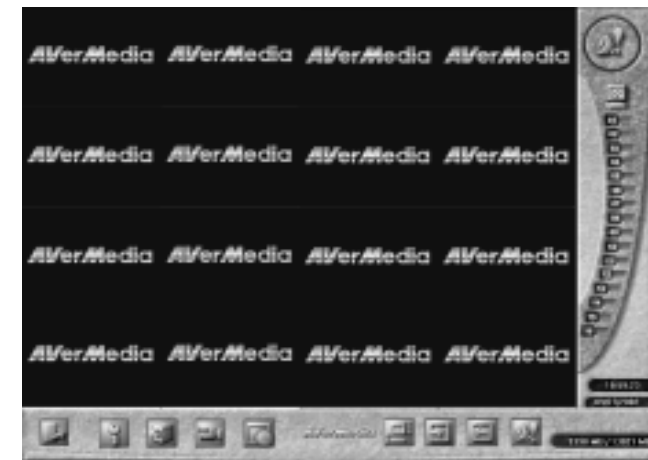



User Management

User Management provides the easy management to safeguard the system from the unidentified users. Only the root is authorized to configure this section.

To achieve the setting, complete the following steps:

1. Click **User Management**. The following window will appear:

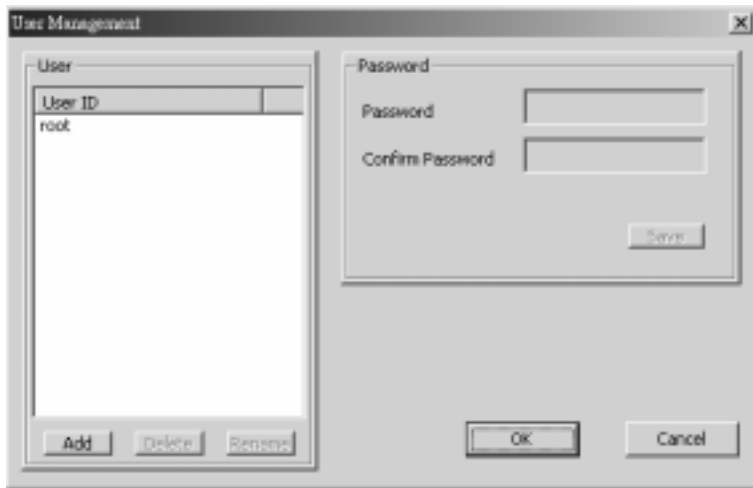

2. Use **Add/Delete/Rename** button to arrange **User** field.
3. Determine a password and make a confirmation.
4. Click **Save** to save the setup of password.
5. Click **OK** to save or **Cancel** to delete the previous arrangement.
6. Back to main menu by clicking



6.2.2 Storage Configuration



Assign Recording Disks

First, you need to assign the recording disks for your folders' storage. Click to browse for the folder to save the recorded videos in a specific path and click **Add** button to create it. Pay a particular attention on the path definition, the path where the recording files locate has built-in a "\USER\ your ID\" folder, i.e., an indicated path "C:\Surveillance\recording" by a root should be searched with the path "C:\Surveillance\recording\USER\root." You can click **Delete** button to remove anyone of the recording disks, as long as there is at least 1 disk left to save the recording data.

Minimum Space & Safety Quota

Next you need to provide the minimum space and safety quota for hard disk recycling. During hard disk recycling, the newly recorded files will overwrite the old ones. This way the system will not run out of hard disk space to save the recorded videos.

Minimum Space:

The system will start hard disk recycling when the hard disk free space is less than a user-defined number. The user-defined number has to be greater than 450MB, the system defaults to 450MB.

Safety Quota:

Once the hard disk starts recycling, the system won't stop until the hard disk free space becomes more than a user-defined number, say 6000MB (default value). **Safety quota should be at least 5550 MB more than the minimum space you assigned.**



6.2.3 Camera Setup

The setting is placed according to the privilege of every server for the cameras corresponding to the 16 channels respectively.

Follow the tasks below to finish this section:

1. Click **Camera Setup**. It will show a window like the following:



2. Change channel's names by directly click on **Channel 1**.
3. Arrow down the list to select the **Server's** and **Camera's** names for each channel.
4. Check **Display** to show the images on the screen and **Recording** to enable the recording function for each channel.
5. Click **OK** to save or **Cancel** to delete the previous arrangement.



The listed servers and cameras in the pull-down menu are decided by the settings of the each of the servers.



6.2.4 Schedule Recording

The function allows you to plan the recording schedule by date or weekday for all the channels.

Do the steps following:



1. Click **Schedule Recording** to get the window besides:



2. Check the recording by date or by weekday and choose the time by clicking the arrow of the box **2002/10/1**. The following window will show as:



3. Click on the yy/mm position directly and use the upper left and upper right arrows and the red circle in the bottom left corner window to specify a date to be an operating time.

4. Click  to confirm the time setting. A settled time will appear on the right blank box. Click **Delete** to delete the previous time setting.
5. Set the **Start** and **End** time by the up and down arrows  in **Time** field.
6. Check the desired cameras to be involved into the schedule in **Camera** field.
7. Mentioned comment is allowed by using **Add/ Delete/ Update/ Restore** buttons for the further information while recording.
8. Click **Ok** to save or **Cancel** to delete the previous arrangement.

Once the recording has been generated as the schedule, the recording status is observed in **Channel Status** field.

6.2.5 Network Setup

If you want to transmit images for remote surveillance via TCP/IP, first click this button to pop up the following dialogue.



1. Select **TCP port** connecting to server via **Auto assignment** or specify at least 32 ports at a range from 1025 to 65535 for transferring image and receiving commands.
2. Click **OK** to save the setting or **Cancel** to quit the dialogue without saving.

The following is the detailed illustration to configure the connection:

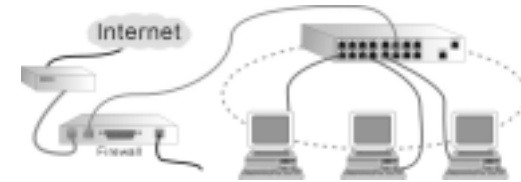

6.2.6 Sensor Status

The sensor status is viewed on the consequent window by clicking this button.





6.2.7 Relay Status

The relay status is viewed on the consequent window by clicking this button. Otherwise, you can set the duration of the relay output after a relay triggered. Note that the duration value "0" denotes the incessant relay output.



6.2.8 Alarm Control

It is available to choose the server and decide to enable or disable the corresponding alarms.

1. Click **Alarm Control** to see the window for alarm status.
2. To enable an alarm, simply click on  in the **Status** column and change the status to .
3. Click the **OK** button to save the setting.



6.2.9 Back to Main Menu

Back to the main menu by clicking this button.

6.3 Operating the RemoteManager

6.3.1 Center Management

Users can take advantage of this section to manage the connectable servers' detailed information. The setting should be placed before you commence configuring the system at the first time.

There are two ways to connect server:

1.  Connection via Modem to Modem (refer to Appendix A for the connection):

First you should connect to the server manually via modem before accessing **RemoteManager**. Then, it is allowed to add a new server as a dial-up server is installed by server and a dial-up networking established by client.

2.  Connection via TCP/IP

Once the function "**Enable Remote View server via TCP/IP**" in the setting of **Networking** section in system configuration has been checked, you are allowed to add a new server via TCP/IP.

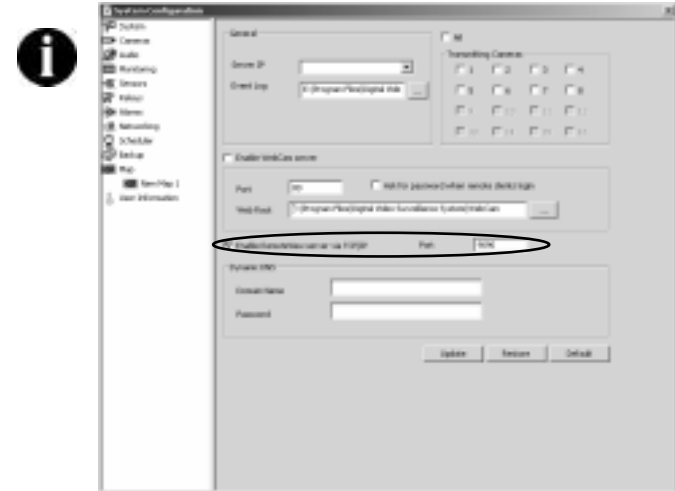

Before arranging center manager section, please make sure RemoteView server enabled in networking section of System Configuration.

To offer the complete information, finish the steps below:

1. Click **Center Manager** button and the following window appears:
2. Click **Add** to include an available server to server list. The **Add Server** window will show as follows or click **Delete** or **Update** to modify the setting.



- The multicast servers in LAN will be listed automatically on the left side of the dialog. You can highlight the server which you want to add and click **OK** or directly double click the server to add a new multicast server.

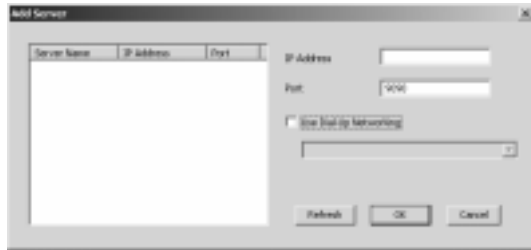

- In order to add a new server in WAN, enter the **IP Address** or domain name of the desired server and the same port number as the setting in Networking section of the server (default 9090). Check **Use Dial-Up Networking** to configure the further setting of network if the network connection is via modem to modem. Click **OK** to start connecting or **Cancel** to quit the dialog.
- The following pop-up window of **Add Server** will show the **Server Name** automatically if the IP Address is correct and has been connected. In that case the server name doesn't show up, please check the connection between server and remote client.

i If the port number has been changed in server end, please delete the server and set a new one.



User

Finish the user's information given by the specified server.

Connecting quality

Here allows user to pick a proper connecting speed for each server to adjust the network quality. Drag the slide bar to select one connecting speed out of 11 levels. Namely, if the update of the image is almost failed, you should to increase the connecting speed. Note that the higher quality needs the higher baud rate. Click **OK** to save to add the new server in center management or **Cancel** to quit the setting.



Note that the connecting speed in remote client had better meet with that in server.

- You will be prompted to click **OK** in the following window to into the **Camera Setup** window once one of the users of server has been deleted. About the instruction of the **Camera Setup**, please refer to **6.2.3 Camera Setup** section.



- Repeat the steps above to add a new server. The maximum numbers of server are limited in 16 for the 16 channels.



6.3.2 Playback

Once in the playback mode, users can view log files recorded in the local/remote hard disks. Click this button and select the kind of file you want for playback: **Local Playback** or **Remote Playback**.



Local Playback

1. Click **Playback** to display the screen below.



2. From the cameras' list shown in time diagram, choose the desired camera folder first and the time folder by yy/mm/dd then. Consequently, the files ranged within the selected time will be listed in time sequence in the file directory.

 The files are located on the local computer so that only the enabled cameras by local user will be found in the file list.

3. Highlight the file you want to review and use the buttons below to control the video playback.



Click this button to playback the selected file.

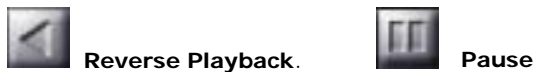

You can drag the slide bar directly to the frame you want to play.



Click the buttons to zoom in or out the images.



You can adjust the brightness, contrast, hue and saturation.



Click the button to print the current image.



Use the playback panel to choose a desired frame and then click **Save** button.



Click the button to delete the current file and make sure by clicking **OK** button on the pop-up window.

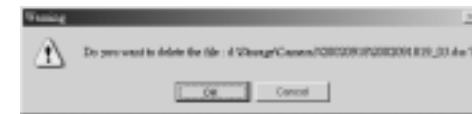

When you review the log files, you can click this button to save the files onto your local disk.

Remote Playback

1. Select **Remote Playback** to configure the further setting



Time

Determine a start time and the duration (up to 60 minutes) by clicking on the arrows.

Channel

Check the desired channels to display while playback.

2. Click **OK** to save the setup or **Cancel** without any saving to enter remote playback window below:



3. Refer to the 2~3 steps in the previous **Local playback** section to view the files.

4. Back to the main menu by clicking 

6.3.3 PTZ Control

Once you have installed a PTZ camera, the functional utility will help you to exert the control on the surveillance.

To enable the function, follow with the steps below:

1. Click **PTZ Control** to show the following window:



2. Designate a channel   ...  connected with PTZ camera for the further setting.



Preset Position Setup

Each PTZ camera can set 16 preset positions. You can move the camera to a desired preset position simply by clicking on the number of the preset position. To set a preset position, first select the number of the preset position and set the direction speed. Then configure the camera's position with the directional control buttons, focus in/focus out buttons, and zoom in/zoom out buttons. Finally set the stay time, rotation speed, and click the **Save** button.



Direction Control

Adjust the camera's direction with the following eight buttons; Up / Down / Left / Right / Upper Left / Bottom Left / Upper Right / Bottom Right.



Direction Speed

There are four speeds to decide the moving speed of the PTZ camera during adjusting **Direction Control**



Focus in

Decrease the focal length of the camera to focus on the image.



Focus out

Increase the focal length of the camera to focus on the image.



Zoom in

Zoom in to enlarge the image of the object.



Zoom out

Zoom out to reduce the image of the object.



Dwell (Sec)

During AutoPan, this button determines the time for the camera to stay (1~60 seconds) at one position before rotating to the next position.



Rotation Speed (deg/s)

You can set the speed (5~255 deg/s) by the left and right arrows at which the camera rotates from its current position to the next preset position.



Save

After you finish setting a preset position, you need to click this button to save it and go on to set the next preset position.



Clear

Click this button to clear the setting for the current preset position.



Group

Each PTZ camera has 4 groups to comply with the position sequences as follows:

Group 1: 1~4 positions

Group 2: 5~8 positions

Group 3: 9~12 positions

Group 4: 13~16 positions



AutoPan

Choose a group number first, and click this button to enable this function.



Back to Main Menu

Click here to back to main menu.

6.4 Start Recording

Manually enable the recording setting arranged in the **Schedule Recording** section by clicking this button. Meanwhile, the recording status is visible in the **Channel Status** field and **Start Recording** button will turn into transparent red.

6.5 Exit RemoteManager

Click this button to exit **RemoteManager**. First a password control window will prompt you to enter the password to make sure your authorization. Then a window below will appear to confirm the quit. Click **OK** to exit or **Cancel** to back to the system



Appendix A Remote Login with an Modem-to-Modem Connection

To run RemoteManager over a direct Modem-to-Modem connection between the AVerMedia EYES Pro/MP2016/MP3000/MP5000 server and the remote client, follow the instructions in the section of the operating system you are using.

 When using Modem-to-Modem connection, if the AVerMedia EYES Pro/MP2016/MP3000/MP5000 server is running on a Windows 98 system, the client cannot login from a Windows 2000 or Windows XP system. **The client can only login from a Windows 98 system when the server is running on a Windows 98 system. It is suggested that the server run with Windows 2000 or Windows XP system.**

A.1 Windows 98SE / Windows Me

1. Server:

- A. Install the Dial-up Server. Go to **Control Panel** and double-click **Add/Remove Programs**. Select the **Windows Setup** tab.



- B. Select Communication and click **Details...**. The **Communication** dialog box will show up. Check the box next to **Dial-up Server** and click the **OK** button.



- C. Click the **OK** button in the **Add/Remove Programs Properties** dialog box and the system will start to install the Dial-up Server. If you're using Windows 98SE, you will be prompted to insert the Windows 98SE CD-ROM.



- D. After finished installing the Dial-up Server, you need to enable the Dial-up Server. Go to **Start→Programs→Accessories→Communications** and click **Dial-up Networking**. You will enter the window below.



- E. Click the **Connections** tab and select **Dial-up Server** to enter the setup page.

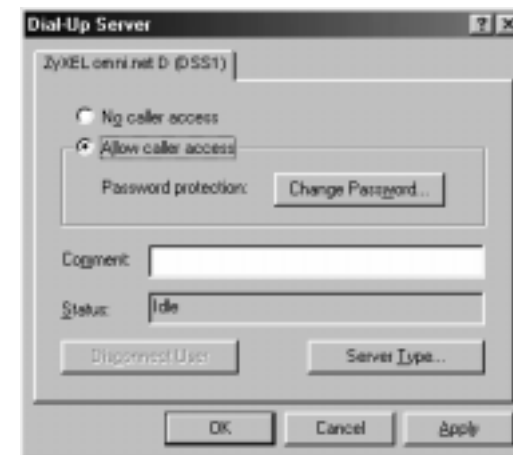

- F. Check **Allow caller access** to enable the Dial-up Server. Click **Change Password...** to set the login password and then click **Server Type...** to change the server type. Select **PPP** from the drop-down menu and then click the **OK** button to finish the ISDN setup for the server end.

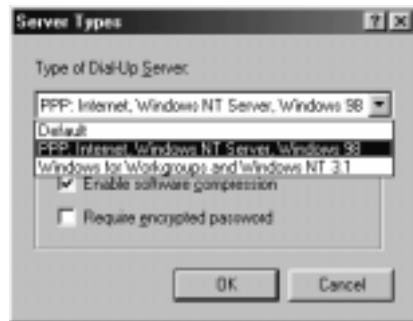

2. Client:

- A. Go to **Start→Programs→Accessories→Communications** and click **Dial-up Networking**. Double-click **Make New Connection** to bring up the **Make New Connection** wizard. Enter the server's name and select the ISDN device you are using. Click the **Next** button to continue.

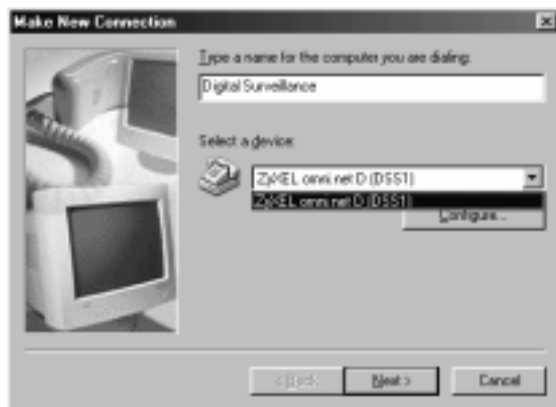

- B. Provide the server's telephone number, including the area code, and click the **Next** button to finish creating the new connection.

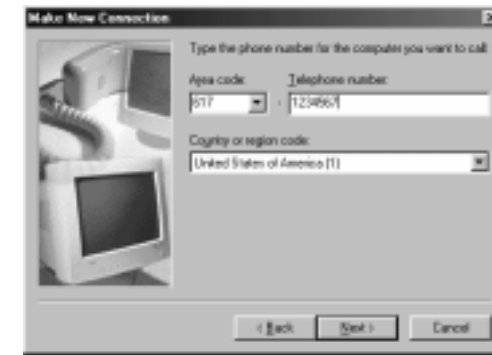

- C. Go back to the **Dial-up Networking** window and double-click the connection you just created. In the **Connect to** dialog box, enter any User name and the Password set in step F of the server's ISDN setup procedure. Click **Connect** to start connecting to the AVerMedia EYES Pro/MP2016/MP3000/MP5000 server.



- D. After you get connected, access **Start → Programs → Digital Video Surveillance System → RemoteManager** to launch RemoteManager. Refer to Chapter 6 RemoteManager to login. (Default IP address: 192.168.55.1)

A.2 Windows 2000

1. Server:

- A. Go to **Start→Programs→Accessories→Communications Wizard**. Click the **Next** button, and click **Network and Dial-up Connections**. In the **Network and Dial-up Connections** window, double-click **Make New Connection** to bring up the **Network Connection**



- B. Select **Accept incoming connections** and click the **Next** button.

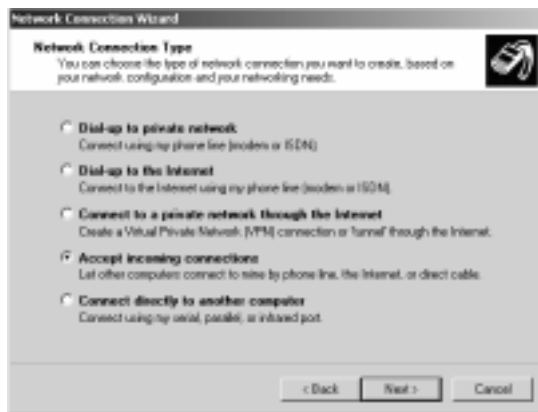

- C. Select the ISDN device you're using and click the **Next** button.



- D. Select **Allow virtual private connections** and click the **Next** button.



- E. Select users allowed to connect to this computer from the list or click **Add...** to create new users. For each user, click **Properties** to set the user's password, which is required when the user login the server. After you finish, click the **Next** button to continue.



- F. Make sure that **Internet Protocol (TCP/IP)** is selected and click **Properties** to enter the **Incoming TCP/IP Properties** dialog box.



- G. Check the boxes next to **Allow callers to access my local area network** and **Specify TCP/IP addresses**. Set the From IP as **192.168.55.1** and the To IP as **192.168.55.2**. Click the **OK** button and then click the **Next** button in the **Network Connection Wizard**.

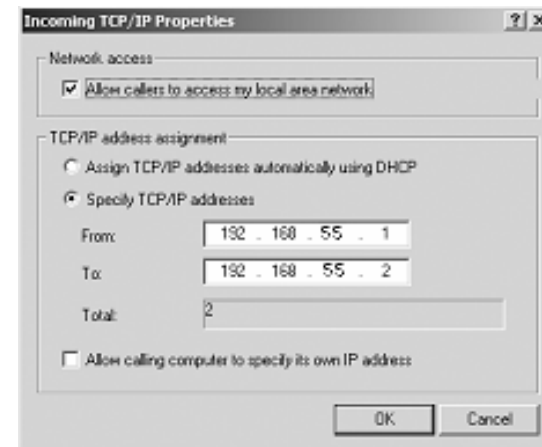

- H. Click the **Finish** button to complete the ISDN setup for the server end.



2. Client:

- A. Go to **Start→Programs→Accessories→Communications** and click **Network and Dial-up Connections**. In the **Network and Dial-up Connections** window, double-click **Make New Connection** to bring up the **Network Connection Wizard**. Click the **Next** button.



- B. Select **Dial-up to private network** and click the **Next** button.



- C. Provide the server's telephone number, including the area code, and click the **Next** button.



- D. Select **For all users** and click the **Next** button.



- E. Click the **Finish** button to complete the connection setup.



- F. Go back to the **Network and Dial-up Connections** window and double-click the connection you just created. In the dialog box, enter any User name and the Password set in step E of the server's ISDN setup procedure. Click **Dial** to start connecting to the AVerMedia EYES Pro/MP2016/MP3000/MP5000 server.



- G. After you get connected, access **Start → Programs → Digital Video Surveillance System → RemoteManager** to launch RemoteManager. Refer to Chapter 6 RemoteManager to login.

A.3 Windows XP

1. Server:

- A. Go to **Start→Programs→Accessories→Communications** and click **New Connection Wizard**. Click the **Next** button.



- B. Select **Set up an advanced connection** and click the **Next** button.



- C. Select **Accept incoming connections** and click the **Next** button.



- D. Select the ISDN device you're using and click the **Next** button.

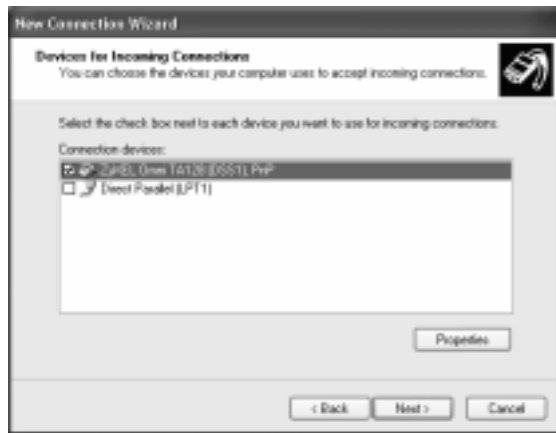

- E. Select **Allow virtual private connections** and click the **Next** button.



- F. Select users allowed to connect to this computer from the list or click **Add...** to create new users. For each user, click **Properties** to set the user's password, which is required when the user login the server. After you finish, click the **Next** button to continue.



- G. Make sure that **Internet Protocol (TCP/IP)** is selected and click **Properties** to enter the **Incoming TCP/IP Properties** dialog box.

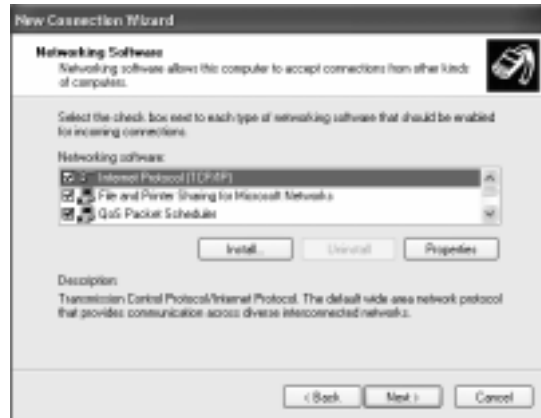

- H. Check the boxes next to **Allow callers to access my local area network** and **Specify TCP/IP addresses**. Set the From IP as **192.168.55.1** and the To IP as **192.168.55.2**. Click the **OK** button and then click the **Next** button in the **Network Connection Wizard**.

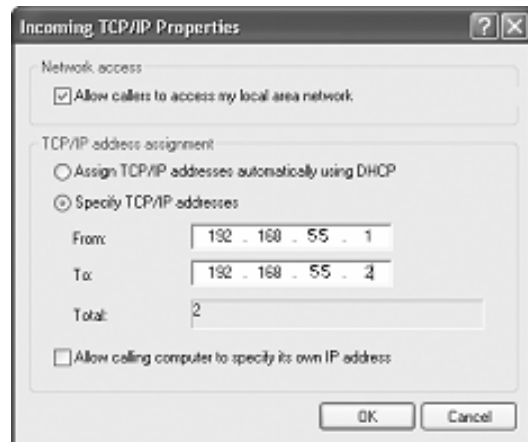

- I. Click the **Finish** button to complete the ISDN setup for the server end.



2. Client:

- A. Go to **Start→Programs→Accessories→Communications** and click **New Connection Wizard**. Click the **Next** button.



B. Select **Connect to the Internet** and click the **Next** button.



C. Select **Set up my connection manually** and click the **Next** button.



D. Select **Connect using a dial-up modem** and click the **Next** button.



E. Enter the name of this connection and click the **Next** button.



- F. Provide the server's telephone number, including the area code, and click the **Next** button.



- G. Enter any User name and the Password set in step F of the server's ISDN setup procedure. Click the **Next** button to continue.



- H. Click the **Finish** button to complete the connection setup.



- I. Go to **Start**→**Programs**→**Accessories**→**Communications** and click **Network Connections**. Double-click the connection you just created. In the dialog box, enter any User name and the Password set in step F of the server's ISDN setup procedure. Click  to start connecting to the AVerMedia EYES Pro/MP2016/MP3000/MP5000 server.



- J. After you get connected, access **Start** → **Programs** → **Digital Video Surveillance System** → **RemoteManager** to launch RemoteManager. Refer to Chapter 6 RemoteManager to login.

Appendix B Registering Domain Name on DDNS Server

DDNS (Dynamic Domain Name Service), a data query service chiefly used on Internet for translating domain names into Internet addresses. It is allowed the remote clients intelligently search dynamic servers without any previous enquiring for servers' Internet addresses.

In order to take advantage of the intelligent service, please first register your domain name on the website: ddns.avers.com.tw

1. User Login

Browse the website ddns.avers.com.tw with Microsoft IE or Netscape Navigator to access the following dialogue.

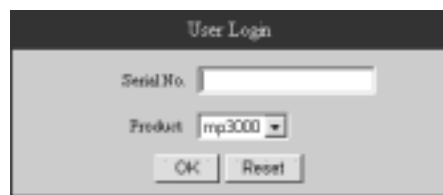

The 'User Login' dialog box contains the following fields and controls:

- Serial No.
- Product
- OK
- Reset

First input the serial number of your product and select the product name. Then click **OK** to login or **Reset** to clear the previous input.

2. Password

Set a password to secure your identification.

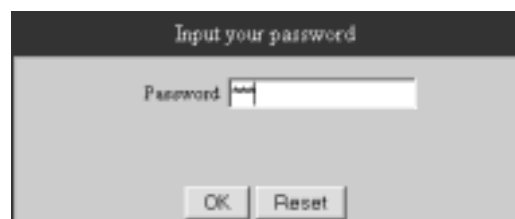

The 'Input your password' dialog box contains the following fields and controls:

- Password
- OK
- Reset

3. User Information

Please provide the following user information, **Host Name**, **Password**, **E-mail**, **Company**, and **Country** to complete the registration procedures.

 Note that Host Name and Domain Name (AVerMedia.avers.com.tw) are the replacement for Internet address while a remote client tends to search a dynamic server.

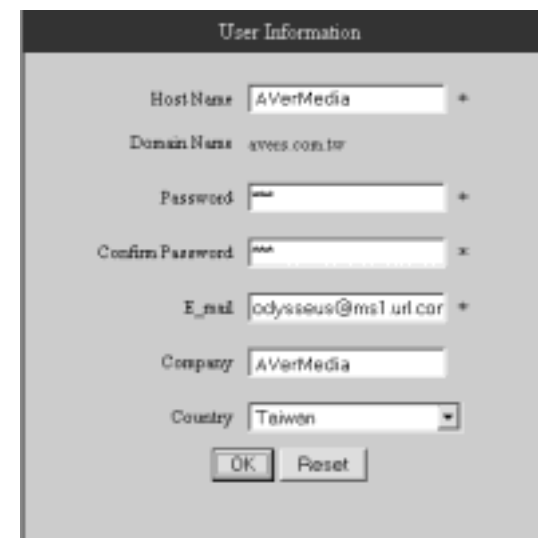

The 'User Information' dialog box contains the following fields and controls:

- Host Name
- Domain Name
- Password
- Confirm Password
- E_mail
- Company
- Country
- OK
- Reset

LIMITED WARRANTY

AVerMedia TECHNOLOGIES, Inc. warrants that this product to be free of defects resulting from faulty manufacturing or components under the following terms:

WARRANTY LENGTH

Labor is warranted for 15 months from the date of purchase.

Replacement products will be warranted for the remainder of the 15-month warranty period or 30 days, whichever is longer.

WHO IS PROTECTED

This warranty is enforceable only by the first consumer purchaser.

WHAT IS AND IS NOT COVERED

Except as specified below, this warranty covers all defects resulting from faulty manufacturing of this product. The following are not covered by the warranty.

1. Any product on which the serial number has been defaced, modified, or removed.
2. Damage, deterioration, or malfunction resulting from:
 - A. Accident, abuse, misuse, neglect, fire, water, lightning, or other acts of nature, commercial or industrial use, unauthorized product modification, or failure to follow instructions included with the product.
 - B. Misapplication of service by someone other than the manufacturer's representative.
 - C. Any shipment damages. (Claims must be made with carriers.)
 - D. Any other cause that does not relate to a product defect.
3. Cartons, cases, batteries, cabinets, tapes, or accessories used with the product.
4. **AVerMedia TECHNOLOGIES, Inc.** does not warrant that this product will meet your requirements; it is **your** responsibility to determine the suitability of this product for your purpose.

WHAT WE WILL AND WILL NOT PAY FOR

We will pay labor and material expenses for covered items. However, we will not pay for the following:

1. Removal or installation charges.
2. Shipping charges.
3. Any incidental charges.

EXCLUSION OF DAMAGES

THE MANUFACTURER'S SOLE OBLIGATION AND LIABILITY UNDER THIS WARRANTY IS LIMITED TO THE REPAIR OR REPLACEMENT OF A DEFECTIVE PRODUCT AT OUR OPTION. THE MANUFACTURER SHALL NOT, IN ANY EVENT, BE LIABLE TO THE PURCHASER OR ANY THIRD PARTY FOR ANY INCIDENTAL OR CONSEQUENTIAL DAMAGE (INCLUDING, BUT NOT LIMITED TO, DAMAGES RESULTING FROM INTERRUPTION OF SERVICE AND LOSS OF BUSINESS) OR LIABILITY LIMITATIONS OF IMPLIED WARRANTIES.

There are no other oral or written warranties, expressed or implied, including but not limited to those of merchantability or fitness for a particular purpose. Any implied warranties are limited in duration to 15 months from the date of purchase.

STATE LAW AND YOUR WARRANTY

This warranty gives you specific legal rights, and you may also have other rights granted under state law. These rights vary from state to state.

CONTACT INFORMATION

Taiwan & International
No. 135, Jian Yi Rd., Chung Ho City, Taipei, Taiwan, R.O.C.
TEL: 886-2-2226-3630
FAX: 886-2-3234-4842
Web Site: www.avers.com.tw